

1962/3

BSA SPARES

20-10366C

**“A” MODELS
TWIN CYLINDER
500 c.c. and 650 c.c.**



CLASSIC
BIKE SPARES

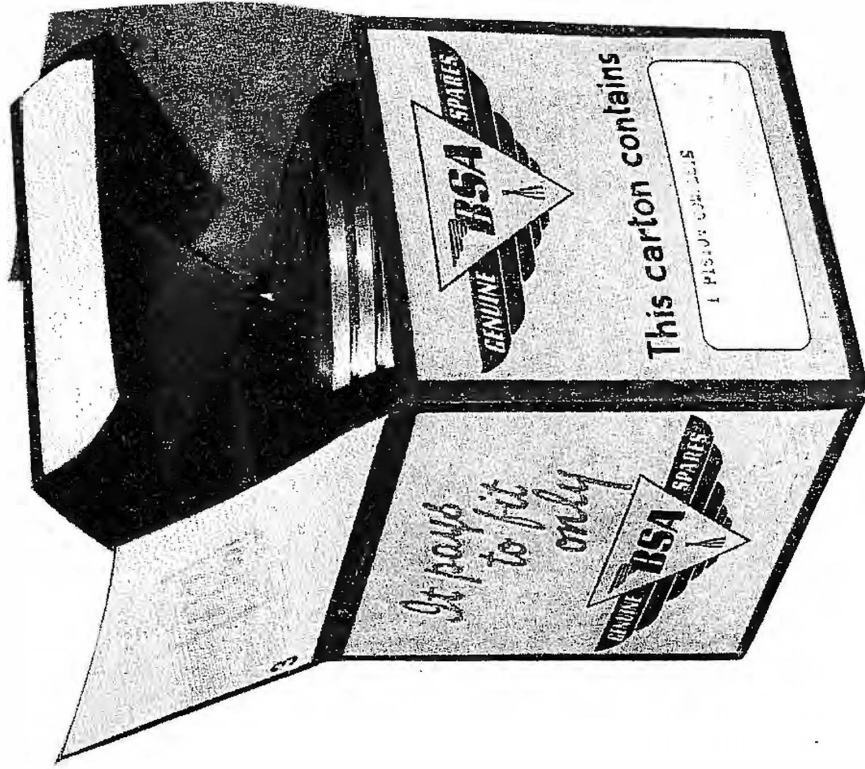

Always use
Genuine
B.S.A.
Spares



**CLASSIC
BIKE SPARES**

**SUFFIX NUMBERS TO BE USED TO IDENTIFY VARYING FINISHES.
CHIFFRES DE SUFFIXE A EMPLOYER POUR IDENTIFIER LES PRÉSENTATIONS VARIÉES.
NACHZAHLEN ZU BENUTZEN UM DIE VERSCHIEDENEN AUSFUHRÜNGEN ZU BEZEICHNEN.
CIFRAS ADICIONALES QUE SE EMPLEA PARA IDENTIFICAR LOS ACABADOS VARIOS.**

When ordering components with varying finishes, please state finish required by adding the APPROPRIATE NUMBER TO PART NUMBER.

En commandant des pièces avec présentations différentes veuillez indiquer la présentation requise en ajoutant les chiffres appropriés au numéro de CATALOGUE DE LA PIECE.

Bei Bestellungen von Teilen mit verschiedenen Ausführungen bitte die Erwünschte Ausführung mit Angabe der entsprechenden Nachzahl nach dem TEILNUMMER BEZEICHNEN.

Al pedir piezas con acabados diferentes sírvase indicar el acabado requerido mediante la cifra relativa escrita después del NUMERO DE CATALOGO DE LA PIEZA.

EXAMPLE. Standard Model, Petrol Tank, Devon Red, 1 83 40-8004./034

EXEMPLE. Réservoir d'essence, Alizarine Carminée 1 83 40-8004./034

BEISPIEL. Benzintank, Alizarinkarmin 1 83 40-8004./034

EJEMPLO. Deposito de combustible, Carmin de Alizarina 1 83 40-8004./034



**ASSEMBLY'S COMPLETE
ENSEMBLE COMPLET
TEILE-MONTAGE KOMPLETT
ASEMBLI COMPLETA**

Model Modèle Typen Modelos	Spares No. No. de pièce Ersatzteil-nr No. de repuesto	Description	Designation	Beschreibung	Descripción
A7	67-0015	Engine complete less electrical equipment and Carburetter.	Moteur complet sans appareillage électrique et carburateur.	Motor, komplett O, Elektr. Ausrüstung u. o. Vergaser.	Motor completo sin equipo eléctrico y carburador.
A7S/S	67-1194	Engine complete less electrical equipment and Carburetter.	Moteur complet sans appareillage électrique et carburateur.	Motor, komplett O, Elektr. Ausrüstung u. o. Vergaser.	Motor completo sin equipo eléctrico y carburador.
A10	42-0133	Engine complete less electrical equipment and Carburetter.	Moteur complet sans appareillage électrique et carburateur.	Motor, komplett O, Elektr. Ausrüstung u. o. Vergaser.	Motor completo sin equipo eléctrico y carburador.
A10S/R	42-0131	Engine complete less electrical equipment and Carburetter.	Moteur complet sans appareillage électrique et carburateur.	Motor, komplett O, Elektr. Ausrüstung u. o. Vergaser.	Motor completo sin equipo eléctrico y carburador.
Spitfire Scrambler	42-0129	Engine complete less electrical equipment and Carburetter.	Moteur complet sans appareillage électrique et carburateur.	Motor, komplett O, Elektr. Ausrüstung u. o. Vergaser.	Motor completo sin equipo eléctrico y carburador.
A Group	42-3250	Gearbox complete less Clutch	Boîte de vitesses sans embrayage.	Getriebegehäuse O, Kupplung	Caja de velocidades sin embrague
Spitfire Scrambler	42-3099	Gearbox complete less Clutch	Boîte de vitesses sans embrayage	Getriebegehäuse O, Kupplung	Caja de velocidades sin embrague
A Group	1 82 42-3264†	Clutch complete	Embrayage complet	Kupplung, komplett	Embrague completa
A7, A7S/S	1 88 67-1089	Crankcase Driveside and Gearside.	Carter de vilebrequin complet	Kurbelgehäuse, komplett	Caja de cigüeñal completa
A10	1 88 67-1077	Crankcase Driveside and Gearside.	Carter de vilebrequin complet	Kurbelgehäuse komplett	Caja de cigüeñal completa
A10S/R	1 91 42-0152	Crankcase Driveside, Gearside with Cover.	Carter de vilebrequin complet avec couvercle.	Kurbelgehäuse, komplett mit Schutzkappe.	Caja de cigüeñal completa con tapa,
A Group	1 95 42-4677	Frame complete with Centre Stand.	Cadre complet avec béquille centrale.	Rahmen, komplett mit Mittelständer.	Cuadro completa con muleta
Spitfire Scrambler	1 95 42-4483	Frame complete with Centre Stand.	Cadre complet avec béquille centrale.	Rahmen, komplett mit Mittelständer.	Cuadro completa con muleta
A7, A7S/S, A10	1 96 42-5127	Front Fork complete	Fourche av complet	Vordergabel, komplett	Horquilla del completa
A10S/R	1 96 42-5128	Front Fork complete	Fourche av complet	Vordergabel, komplett	Horquilla del completa
Spitfire Scrambler	1 98 42-5314	Front Fork complete	Fourche av complet	Vordergabel, komplett	Horquilla del completa
A7	1 87 42-5806	Front Wheel complete with Spindle and Bearings.	Roue av complet	Vorderrad, komplett	Rueda del completa
A7S/S, A10	1 87 42-5803	Front Wheel complete with Spindle and Bearings.	Roue av complet	Vorderrad, komplett	Rueda del completa
A10/S/R, Spitfire Scrambler	1 87 42-5804	Front Wheel complete with Spindle and Bearings.	Roue av complet	Vorderrad, komplett	Rueda del completa
A7	1 79 42-5807	Front Hub complete with Spindle and Bearings.	Moyeu de roue av complet	Vorderradnabe, komplett	Cuebo de rueda del completa
A7S/S, A10, A10S/R	1 79 42-5805	Front Hub complete with Spindle and Bearings.	Moyeu de roue av complet	Vorderradnabe, komplett	Cuebo de rueda del completa
A7, A7S/S, A10	1 86 42-6308	Rear Wheel complete with Spindle and Bearings.	Roue ar complet	Hinterrad, komplett	Rueda trasera completa
A10S/R Spitfire Scrambler	1 86 42-6338	Rear Wheel complete with Spindle and Bearings.	Roue ar complet	Hinterrad, komplett	Rueda trasera completa
A Group	1 78 42-6309	Rear Hub with Spindle and Bearings.	Moyeu de roue ar complet	Hinterradnabe, komplett	Cuebo de rueda trasera completa
A Group	1 75 42-4899	Front Safety Bar with fittings.	Parachoc av monté	Stürzbogen m. Zubehör	Defensa del montada
A Group	1 63 42-4909	Rear Safety Bar complete	Ensemble de parachoc ar complet	Hintere Stürzbogen, komplett	Conjunto de defensa trasera comp.
A Group	1 69 42-7205	Legshields complete	Protege-jambes complet	Beinschutz komplett	Guardapiernas completa
A Group	1 78 42-7214	Legshield and Front Safety Bar complete.	Protege-jambes et pare-chocs complet.	Beinschutz und Stürzbogen komplett.	Guardabarros y defensas completa
A7, A7S/S, A10	1 51 67-1402	Oil Pump Complete	Pompe à huile complet	Ölpumpe, komplett	Bomba de aceite completa
A10S/R	1 52 42 0155	Oil Pump complete	Pompe à huile complet	Ölpumpe, komplett	Bomba de aceite completa

MODELS AND COMPONENTS WITH VARIOUS FINISHES
 MODELES ET PIECES AVEC PRESENTATIONS VARIÉES
 MODELLE UND TEILE VERSCHIEDENER AUSFÜHRUNGEN
 MODELOS Y PIEZAS CON ACABADOS DIFERENTES

Description Designation Beschreibung Descripción	Model Modèle Typen Modelos	Model Modèle Typen Modelos	Model Modèle Typen Modelos	Model Modèle Typen Modelos
	A7	A7S/S	A10	A10S/R
Frame, Fork ... Cadre, fourche av ... Rahmen, Vordergabel Cuadro, horquilla def.	Black ... /007 Noir ... /007 Schwarz ... /007 Negro ... /007	Black ... /007 Noir ... /007 Schwarz ... /007 Negro ... /007	Black ... /007 Noir ... /007 Schwarz ... /007 Negro ... /007	Black ... /007 Noir ... /007 Schwarz ... /007 Negro ... /007
Petrol Tank ...	Devon Red and Chrome ... /142 *Black & Chrome ... /120	Metallic Green & Chrome ... /038	Silver Beige & Chrome ... /026 *Blue & Chrome ... /146 *Black & Chrome ... /120	Royal Red & Chrome ... /109 *Black & Chrome ... /120 *Metallic Grey & Chrome ... /127
Reservoir d'essence ...	Alizarine carminée et chrome /142 *Noir et chrome ... /120	Vert polychromé et chrome /038	Beige et chrome ... /026 *Bleu et chrome ... /146 *Noir et chrome ... /120	Rouge royale et chrome ... /109 *Noir et chrome ... /120 *Gris polychromé et chrome ... /127
Benzintank ...	Alizarinkarmin mit Chromfeldern ... /142 *Schwarz mit Chromfeldern /120	Grün mit Chromfeldern ... /038	Beige mit Chromfeldern ... /026 *Blau mit Chromfeldern ... /146 *Schwarz mit Chromfeldern ... /120	Karmin-Rot mit Chromfeldern /109 *Schwarz mit Chromfeldern ... /120 *Grau mit Chromfeldern ... /127
Deposito de combustible	Carmin de alizarina y cromado ... /142 *Negro y cromado ... /120	Verde policromático ... /038	Dorado y cromado ... /026 *Azul y cromado ... /146 *Negro y cromado ... /120	Rojo real y cromado ... /109 *Negro y cromado ... /120 *Gris policromático y cromado /127
Oil Tank ...	Devon Red ... /034 *Black ... /007	Metallic Green ... /039	Polychromatic Silver Beige ... /024 *Black ... /007 *Nutley Blue ... /088	Black ... /007 *Metallic Princess Grey ... /102
Reservoir d'huile ...	Alizarine carminée ... /034 *Noir ... /007	Oxyde de chrome trans ... /039	Beige argentie polychromatique /024 *Noir ... /007 *Bleu de cobalt ... /088	Noir ... /007 *Noir d'ivoire ... /102
Oiltank ...	Alizarinkarmin ... /034 *Schwarz ... /007	Chromoxydgrün Trans ... /039	Polychromatisches Silber Beige /024 *Schwarz ... /007 *Kobaltblau ... /088	Schwarz ... /007 *Elfenbeinschwarz ... /102
Deposito de aceite ...	Carmin de alizarina ... /034 *Negro ... /007	Oxido de cromo trans ... /039	Beige-argento polycromático /024 *Negro ... /007 *Azul de cobalto ... /088	Negro ... /007 *Negro de marfil ... /102

*Indicates alternative finishes.

*Indique des présentations alternatives.

*Bezeichnet Wahlweise Ausführungen.

*Indica acabados alternativos.

CLASSIC
 BIKE SPARES

**MODELS AND COMPONENTS WITH VARIOUS FINISHES
 MODELES ET PIECES AVEC PRESENTATIONS VARIEES
 MODELLE UND TEILE VERSCHIEDENER AUSFUHRUNGEN
 MODELOS Y PIEZAS CON ACABADOS DIFERENTES**

Description Designation Beschreibung Descripción	Model Modèle Typen Modelos	Model Modèle Typen Modelos	Model Modèle Typen Modelos	Model Modèle Typen Modelos
	A7	A7S/S	A10	A10S/R
Toolbox	Devon Red /034 *Black /007	Metallic Green /039	Polychromatic Silver Beige ... /024 *Black /007 *Nutmeg Blue /088	Black /007 *Metallic Princess Grey ... /102
Boite a outils	Alizarine carminée /034 *Noir /007	Oxyde de chrome trans ... /039	Beige argentie polychromatique /024 *Noir /007 *Bleu de cobalt /088	Noir /007 *Noir d'ivoire /102
Werkzeugkasten	Alizarinkarmin /034 *Schwarz /007	Chromoxydgrün Trans ... /039	Polychromatisches Silber-Beige /024 *Schwarz /007 *Kobaltblau /088	Schwarz /007 *Elfenbeinschwarz /102
Caja de herramientas	Carmin de alizarina ... /034 *Negro /007	Oxido de cromo trans ... /039	Beige argento polycromatico ... /024 *Negro /007 *Azul de cobalto /088	Negro /007 *Negro de marfil /102
Mudguards	Devon Red /034 *Black /007	Metallic Green /039	Polychromatic Silver Beige ... /024 *Black /007 *Nutmeg Blue /088	Royal Red /027 *Black /007 *Metallic Princess Grey ... /102
Gardeboue	Alizarine carminée /034 *Noir /007	Oxyde de chrome trans ... /039	Beige argentie polychromatique /024 *Noir /007 *Bleu de cobalt /088	Rouge Royale /027 *Noir /007 *Noir d'ivoire /102
Schutzbleche	Alizarinkarmin /034 *Schwarz /007	Chromoxydgrün Trans ... /039	Polychromatisches Silber-Beige /024 *Schwarz /007 *Kobaltblau /088	Karmin-Rot /027 *Schwarz /007 *Elfenbeinschwarz /102
Guardabarros	Carmin de alizarina ... /034 *Negro /007	Oxido de cromo trans ... /039	Beige argento polycromatico ... /024 *Negro /007 *Azul de cobalto /088	Rojo real /027 *Negro /007 *Negro de marfil /102

*Indicates alternative finishes.
 *Indique des presentations alternatives.
 *Bezeichnet Wahlweise Ausführungen.
 *Indica acabados alternativos.



**PISTON CHART
TABLEAU DES PISTONS
KOLBENTABELLE
GRAFICO DE EMBOLOS**

Model Modèle Typen Modelos	Compression Ratio Taux de compression Verdichtungsverhältnis Compresion	PISTON COMPLETE PISTON COMPLET KOLBEN KOMPLETT EMBOLO COMPLETA			COMPRESSION RING SEGMENT DE COMPRESSION VERDICHTUNGSRING ANILLO DE COMPRESION			PISTON RING (BOTTOM) SEGMENT (INFERIEUR) KOLBENRING (UNTER) SEGMENTO (INFERIOR)		
		Standard Montante	+ 1/2 mm.	+ 1 mm.	Standard Montante	+ 1/2 mm.	+ 1 mm.	Standard Montante	+ 1/2 mm.	+ 1 mm.
A7	7.25	1 51 67-1422(2)	1 51 67-1424(2)	1 51 67-1426(2)	1 16 67-0407(4)	1 16 67-0408(4)	1 16 67-0409(4)	1 18 67-0410(2)	1 18 67-0411(2)	1 18 67-0412(2)
A7S/S	8.0	1 51 67-1442(2)	1 51 67-1444(2)	1 51 67-1446(2)	1 16 67-0407(4)	1 16 67-0408(4)	1 16 67-0409(4)	1 18 67-0410(2)	1 18 67-0411(2)	1 18 67-0412(2)
*500 Flash ..	8.0	1 51 67-1442(2)	1 51 67-1444(2)	1 51 67-1446(2)	1 16 67-0407(4)	1 16 67-0408(4)	1 16 67-0409(4)	1 18 67-0410(2)	1 18 67-0411(2)	1 18 67-0412(2)
*A7S/S	8.5	1 51 67-1558(2)	1 51 67-1560(2)	1 51 67-1562(2)	1 16 67-0407(4)	1 16 67-0408(4)	1 16 67-0409(4)	1 18 67-0410(2)	1 18 67-0411(2)	1 18 67-0412(2)
A10	7.25	1 51 67-1416(2)	1 51 67-1418(2)	1 51 67-1420(2)	1 16 67-0311(4)	1 16 67-0312(4)	1 16 67-0313(4)	1 18 67-0314(2)	1 18 67-0315(2)	1 18 67-0316(4)
*Royal Tourist	8.3	1 51 67-1370(2)	1 51 67-1372(2)	1 51 67-1374(2)	1 16 67-0311(4)	1 16 67-0312(4)	1 16 67-0313(4)	1 18 67-0314(2)	1 18 67-0315(2)	1 18 67-0316(2)
A10	8.26	1 51 67-1370(2)	1 51 67-1372(2)	1 51 67-1374(2)	1 16 67-0311(4)	1 16 67-0312(4)	1 16 67-0313(4)	1 18 67-0314(2)	1 18 67-0315(2)	1 18 67-0316(2)
A10S/R	8.26	1 51 67-1370(2)	1 51 67-1372(2)	1 51 67-1374(2)	1 16 67-0311(4)	1 16 67-0312(4)	1 16 67-0313(4)	1 18 67-0314(2)	1 18 67-0315(2)	1 18 67-0316(2)
*Spitfire Scrambler ..	8.75	1 51 67-1552(2)	1 51 67-1554(2)	1 51 67-1556(2)	1 16 67-0311(4)	1 16 67-0312(4)	1 16 67-0313(4)	1 18 67-0314(2)	1 18 67-0315(2)	1 18 67-0316(2)
*A10S/R	8.75	1 51 67-1552(2)	1 51 67-1554(2)	1 51 67-1556(2)	1 16 67-0311(4)	1 16 67-0312(4)	1 16 67-0313(4)	1 18 67-0314(2)	1 18 67-0315(2)	1 18 67-0316(2)

*American type.

*Type American.

*Amerikanische Typen

*Tipo Americano.



**CLASSIC
BIKE SPARES**

CARBURETTERS
CARBURATEURS
VERGASER
CARBURADORES

AMAL LTD., HOLFORD ROAD, WITTON, BIRMINGHAM, ENGLAND.

Model Modèle Typen Modelos	Spares No. No. de pièce Ersatzteil Nr No. de repuesto	Makers No. No. du fabricant Hersteller Nr No. fabricante	Main Jet Gicleur principal Hauptdüse Surtidor principal	Pilot Jet Gicleur de ralenti Leerlaufdüse Surtidor pilote	Throttle Slide Boisseau des gaz Gasschieber Corredera de aceleración	Needle Jet Gicleur d'aiguille Nadeldüse Surtidor de aguja	Needle Position Position d'aiguille Nadel position Posición de aguja
A7	8 73 42-0171	376/238	210	25	376/3½	.106	2
A7S/S	8 73 42-0172	376/239	270	30	376/3½	.106	3
A10	8 74 42-0173	389/45	250	30	389/3½	.106	3
A10S/R	8 90 42-0170	T10. T.T.9	410	—	7	.109	4
A10S/R	8 74 42-0177	389/46 Monobloc	420	25	389/3	.106	2
*500 Flash	8 73 67-1183	376/212	210	25	376/3½	.106	2
*A7S/S	8 73 67-1184	376/213	270	30	376/3½	.106	3
*Royal Tourist	8 74 42-0176	389/48	250	30	389/3½	.106	3
*Spitfire Scrambles	8 74 42-0169	389/47	290	25	389/3	.106	2
*A10S/R	8 74 42-0169	389/47	290	25	389/3	.106	2
*Spitfire Scrambles	8 90 42-0170	T10. T.T.9	410	—	7	.109	4
*A10S/R	8 90 42-0170	T10. T.T.9	410	—	7	.109	4

*American type

*Type American

*Amerikanische Typen

*Tipo Americano

CLASSIC
BIKE SPARES

INDEX, GRUPPEVERZEICHNIS, INDICE

PAGE
SEITE
PAGINA

Rocker Box Oil Feed Pipe	Boitier des culbuteurs Tuyauterie d'alimentation d'huile	Kipphebelgehäuse Ölzufuhrleitung	Carter des los brazos oscilantes Tubo de alimentacion de aceite	12 - 13
Cylinder Cylinder Head	Cylindre Culasse	Zylinder Zylinderkopf	Cilindro Culata	14 - 17
Crankshaft Exhaust Pipe	Vilebrequin Tuyau d'échappement	Kurbelwelle Auspuffrohr	Cigüeñal Tubo de escape	18 - 19
Crankshaft Piston	Vilbrequin Piston	Kurbelwelle Kolben	Ciguëñal Embolo	20 - 21
Crankcase Oil Pump	Carter de vilebrequin Pompe á huile	Kurbelgehäuse Ölpumpe	Caja de ciguëñal Bomba de aceite	22 - 25
Crankcase Inner Cover Outer Cover	Carter de vilebrequin Couvercle intérieur Couvercle extérieur	Kurbelgehäuse Innere Schutzkappe Aussen Schutzkappe	Caja de ciguëñal Tapa int. Tapa exterior	26 - 27
Cush Drive Camshaft	Transmission Amortie Arbre de canes	Pufferantrieb Nockenwelle	Mando Amortiguado Arbol de levas	28 - 29
Footstart and Footchange	Kick-start et selecteur a pied	Fusstart und Fuss-Schaltung	Arrancador y canibio de pies	30 - 31
Gear Cluster	Jeu d'engrenages	Zahnradatz	Juego de engranajes	32 - 35
Gearbox	Boîte de vitesses	Getriebe	Caja de velocidades	36 - 37
Clutch Primary Cover	Embrayage Couvercle primaire	Kupplung Primarkappe	Embrague Tapa primario	38 - 41
Frame Prop Stand Battery Holder	Cadre Bequille lateral Support de batterie	Rahmen Seitenstutze Batteriehälter	Cuadro Muleta lateral Porta-bateria	42 - 43
Engine Plates Footrests	Plaque d'appui pour moteur Repose-pied	Motorabstützblech Fussraste	Placa de apoyo del motor Descansa-pie	44 - 45
Engine Plates Air Filter	Plaque d'appui pour moteur Filtre á air	Motorabstützblech Luftfilter	Placa de apoyo del motor Filtro de air	46 - 47

INDEX, GRUPPEEVERZEICHNIS, INDICE,

PAGE
SEITE
PAGINA

Swinging Arm Shock Absorber	Bras oscillant Amortisseur	Schwingarm Stossdämpfer	Horquilla oscilante Amortiguador	48 - 49
Front Fork	Fourche av	Vordergabel	Horquilla del.	50 - 53
Front Wheel	Roue av	Vorderrad	Rueda delantera	54 - 55
Rear Wheel	Roue ar	Hinterrad	Rueda trasera	56 - 57
Mudguards	Garde-boue	Schutzbleche	Guardabarros	58 - 61
Chainguard Brake Pedal	Carter de chaîne Pedale de frein	Kettenkasten Fussbremshebel	Guardacadena Pedal de freno	62 - 63
Petrol Tank	Réservoir d'essence	Benzintank	Deposito de combustible	64 - 67
Oil Tank Tool Box Silencer	Réservoir d'huile Boîte à outils Silencieux	Öltank Werkzeugkasten Schalldämpfer	Deposito de aceite Caja de herramientas Silenciador	68 - 69
Handlebar Dual Seat	Guidon Selle double	Lenker Doppelsitz	Manillar Asiento doble	70 - 73
Safety Bars Carrier Handrail	Pare-chocs Porte-bagages Poignée	Sturzbügel Gepäckträger Haltering	Baras de seguridad Porta-equipaje Puño	74 - 75
Legshields Safety Bars	Protège-jambes Pare-chocs	Beinschutz Sturzbügel	Guardapiernas Baras de seguridad	76 - 77
Legshields Carrier	Protège-jambes Porte-bagages	Beinschutz Gepäckträger	Guardapiernas Porta-equipaje	78 - 79
Equipment	Equipement	Ausrüstung	Equipo	80 - 83
Tools Sundries	Outils Pièces diverses	Werkzeug Sonstige Teile	Herramientos Piezas varias	84 - 85



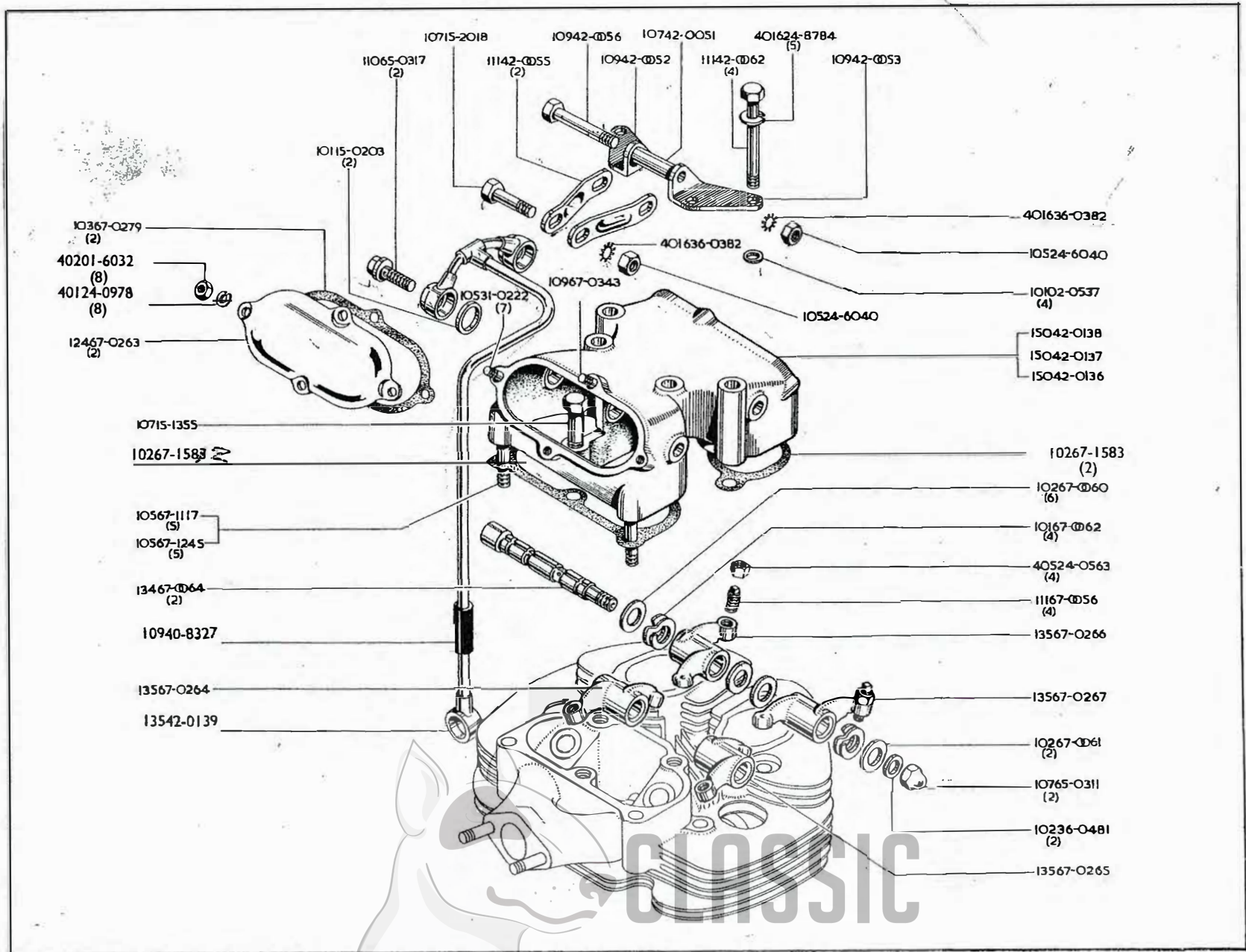

CLASSIC
BIKE SPARES

**ROCKER BOX
BOÎTIER DES CULBUTEURS
KIPPHEBELGHÄUSE
CARTER DES LOS BRAZOS OSCILANTES**

**OIL FEED PIPE
TUYAUTERIE D'ALIMENTATION D'HUILE
ÖLZUFUHRLEITUNG
TUBO DE ALIMENTACIÓN DE ACEITE**

Model Modèle Typen Modelos	Spare No. No. de pièce Ersatzteil-Nr. No. de repuesto	Description	Designation	Beschreibung	Descripción	Per Set Par jeu Pr. Satz Juego de
A Group	4 02 01-6032	Nut	Écrou	Mutter	Tuerca	8
A Group	1 01 02-0537	Washer	Rondelle	Scheibe	Arandela	4
A Group	1 01 15-0203	Sealing Washer	Joint d'étanchéité	Dichtung	Arandela de reten	2
A Group	1 07 15-1355	Bolt	Boulon	Schraube	Tornillo	
A Group	1 07 15-2018	Bolt	Boulon	Schraube	Tornillo	
A Group	4 05 24-0563	Nut	Écrou	Mutter	Tuerca	4
A Group	4 01 24-0978	Lockwasher	Rondelle frein	Sicherungsscheibe	Freno	8
A Group	1 05 24-6040	Nut	Écrou	Mutter	Tuerca	2
A Group	4 01 24-8784	Lockwasher	Rondelle frein	Sicherungsscheibe	Freno	5
A Group	1 05 31-0222	Stud	Goujon	Stehbolzen	Esparago	7
A Group	4 01 36-0382	Lockwasher	Rondelle frein	Sicherungsscheibe	Freno	2
A Group	1 02 36-0481	Sealing Washer	Joint d'étanchéité	Dichtung	Arandela de reten	2
A Group	1 09 40-8327	Rubber Sleeve	Douille caoutchouc	Gunmimuffe	Manguita de goma	
A Group	1 07 42-0051	Distance Piece	Entretoise	Distanzrohr	Distanciador	
A Group	1 09 42-0052	Bracket (left-hand)	Support (gauche)	Verstrebung (links)	Soporte (izq.)	
A Group	1 09 42-0053	Bracket (right-hand)	Support (droite)	Verstrebung (rechts)	Soporte (der.)	
A Group	1 11 42-0055	Stay	Tringle	Strebe	Tirante	2
A Group	1 09 42-0056	Bolt	Boulon	Schraube	Tornillo	
A Group	1 11 42-0062	Bolt	Boulon	Schraube	Tornillo	4
A7S/S ...	1 50 42-0136	Rocker Box	Boîtier des culbuteurs	Kipphebelgehäuse	Carter des los brazos oscilantes	
A10S/R	1 50 42-0137	Rocker Box	Boîtier des culbuteurs	Kipphebelgehäuse	Carter des los brazos oscilantes	
A7, A10	1 50 42-0138	Rocker Box	Boîtier des culbuteurs	Kipphebelgehäuse	Carter des los brazos oscilantes	
A Group	1 35 42-0139	Oil Feed Pipe complete	Tuyauterie d'alimentation d'huile	Ölzufuhrleitung	Tubo de alimentación de aceite	
A Group	1 07 65-0311	Domed Nut	Écrou borgne	Hutmutter	Tuerca abovedada	2
A Group	1 10 65-0317	Union Screw	Vis de raccord	Schraube	Tornillo	2
A Group	1 11 67-0056	Screw	Vis	Schraube	Tornillo	4
A Group	1 02 67-0060	Thrust Washer	Rondelle de butée	Druckscheibe	Anillo de empuje	6
A Group	1 02 67-0061	Thrust Washer	Rondelle de butée	Druckscheibe	Anillo de empuje	2
A Group	1 01 67-0062	Spring	Ressort	Feder	Resorte	4
A Group	1 34 67-0064	Rocker Shaft	Axe des culbuteurs	Kipphebelwelle	Eje de cambio de marche	2
A Group	1 24 67-0263	Cover	Couvercle	Schutzkappe	Tapa	2
A Group	1 35 67-0264	Inlet Rocker (left-hand)	Culbuteur-admission (gauche)	Einlasskipphebel (links)	Brazo osc. admisión (izq.)	
A Group	1 35 67-0265	Inlet Rocker (right-hand)	Culbuteur-admission (droite)	Einlasskipphebel (rechts)	Brazo osc. admisión (der.)	
A Group	1 35 67-0266	Exhaust Rocker (left-hand)	Culbuteur-échappement (gauche)	Ausslasskipphebel (links)	Brazo osc. escape (izq.)	
A Group	1 35 67-0267	Exhaust Rocker (right-hand)	Culbuteur-échappement (droite)	Ausslasskipphebel (rechts)	Brazo osc. escape (der.)	
A Group	1 03 67-0279	Gasket	Joint	Dichtung	Empaquetadura	2
A Group	1 09 67-0343	Stud	Goujon	Stehbolzen	Esparago	2
A7S/S, A10S/R	1 05 67-1117	Stud	Goujon	Stehbolzen	Esparago	5
A7, A10	1 05 67-1245	Stud	Goujon	Stehbolzen	Esparago	5
A Group	1 02 67-1582	Gasket	Joint	Dichtung	Empaquetadura	2
A Group	1 02 67-1583	Gasket	Joint	Dichtung	Empaquetadura	

Abreviations }
 Abréviations } A7S/S — A7 "Shooting Star"
 Abkürzungen } A10S/R — A10 "Super Rocket"
 Abreviacion }

**CLASSIC
BIKE SPARES**

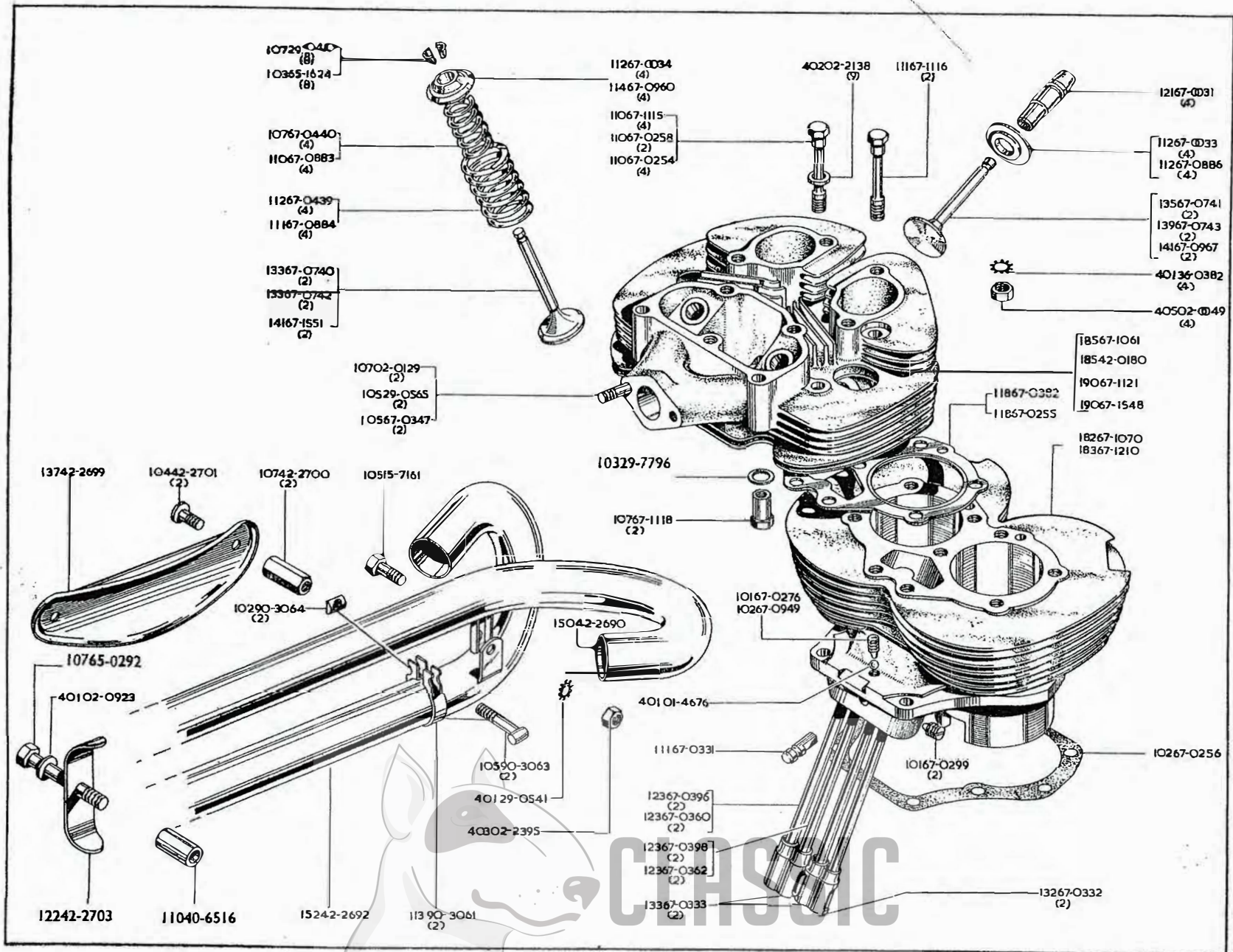

CLASSIC
 BIKE SPARES

**CYLINDER
CYLINDRE
ZYLINDER
CILINDRO**

**CYLINDER HEAD
CULASSE
ZYLINDERKOPF
CULATA**

Model Modèle Typen Modelos	Part No. No. de pièce Bestell-nr No. de parte	Description	Designation	Beschreibung	Descripción	Per Set Par jeu Pr. Satz Juego de
A Group ...	4 01 01-4676	Ball	Bille	Kugel	Bola	
A Group ...	4 05 02-0049	Nut	Écrou	Mutter	Tuerca	4
A7, A10 ...	1 07 02-0129	Stud	Goujon	Stehbolzen	Esparago	2
Spitfire Scrambler ...	4 01 02-0923	Washer	Rondelle	Scheibe	Arandela	
A Group ...	4 02 02-2138	Washer	Rondelle	Scheibe	Arandela	9
Spitfire Scrambler ...	4 03 02-2395	Nut	Écrou	Mutter	Tuerca	
Spitfire Scrambler ...	1 05 15-7161	Bolt	Boulon	Schraube	Tornillo	
A7, A7S/S, A10 ...	1 07 29-0410	Collet	Collet	Keil	Refuerzo del cilindro	
Spitfire Scrambler ...	4 01 29-0541	Lockwasher	Rondelle frein	Sicherungsscheibe	Freno	
A7S/S ...	1 05 29-0565	Stud	Goujon	Stehbolzen	Esparago	2
A7S/S, A10S/R ...	1 03 29-7796	Washer	Rondelle	Scheibe	Arandela	4
A Group ...	4 01 36-0382	Lockwasher	Rondelle frein	Sicherungsscheibe	Freno	4
Spitfire Scrambler ...	1 10 40-6516	Distance Piece	Entretoise	Distanzrohr	Distanciador	
A10 ...	1 85 42-0180	Cylinder Head	Culasse	Zylinderkopf	Culata	
Spitfire Scrambler ...	1 50 42-2690	Exhaust Pipe (o/s)	Tuyau d'échappement (droite)	Auspuffrohr (rechts)	Tubo de escape (der.)	
Spitfire Scrambler ...	1 52 42-2692	Exhaust Pipe (n/s)	Tuyau d'échappement (gauche)	Auspuffrohr (links)	Tubo de escape (izq.)	
Spitfire Scrambler ...	1 37 42-2699	Cover Plate	Plaque couvercle	Abdeckplatte	Tapa del cojinete	
Spitfire Scrambler ...	1 07 42-2700	Nut	Écrou	Mutter	Tuerca	2
Spitfire Scrambler ...	1 04 42-2701	Screw	Vis	Schraube	Tornillo	2
Spitfire Scrambler ...	1 22 42-2703	Clip	Bride	Klammer	Grapa	
Spitfire Scrambler ...	1 07 65-0292	Bolt	Boulon	Schraube	Tornillo	
A10S/R ...	1 03 65-1624	Collet	Collet	Keil	Refuerzo del cilindro	8
A7, A10 ...	1 21 67-0031	Valve Guide	Guide de soupape	Ventilführung	Guía de válvula	4
A7, A7S/S, A10 ...	1 12 67-0033	Spring Cup	Siege de ressort	Federhülse	Copa	4
A7, A7S/S, A10 ...	1 12 67-0034	Collar	Bague d'arrêt	Stelling	Anillo móvil aprisionado	4
A7, A10 ...	1 10 67-0254	Bolt	Boulon	Schraube	Tornillo	4
A10, A10S/R ...	1 18 67-0255	Gasket	Joint	Dichtung	Empaquetadura	
A Group ...	1 02 67-0256	Gasket	Joint	Dichtung	Empaquetadura	
A7, A10 ...	1 10 67-0258	Bolt	Boulon	Schraube	Tornillo	4
A7, A7S/S ...	1 01 67-0276	Screw	Vis	Schraube	Tornillo	
A Group ...	1 01 67-0299	Screw	Vis	Schraube	Tornillo	2
A Group ...	1 11 67-0331	Peg	Ergot	Stift	Esparago	
A Group ...	1 32 67-0332	Tappet (inlet)	Poussoir (d'admission)	Stößel (einlass)	Botador de valvula (admisión)	2
A Group ...	1 33 67-0333	Tappet (exhaust)	Poussoir (d'échappement)	Stößel (auslass)	Botador de valvula (escape)	2

CLASSIC
BIKE SPARES

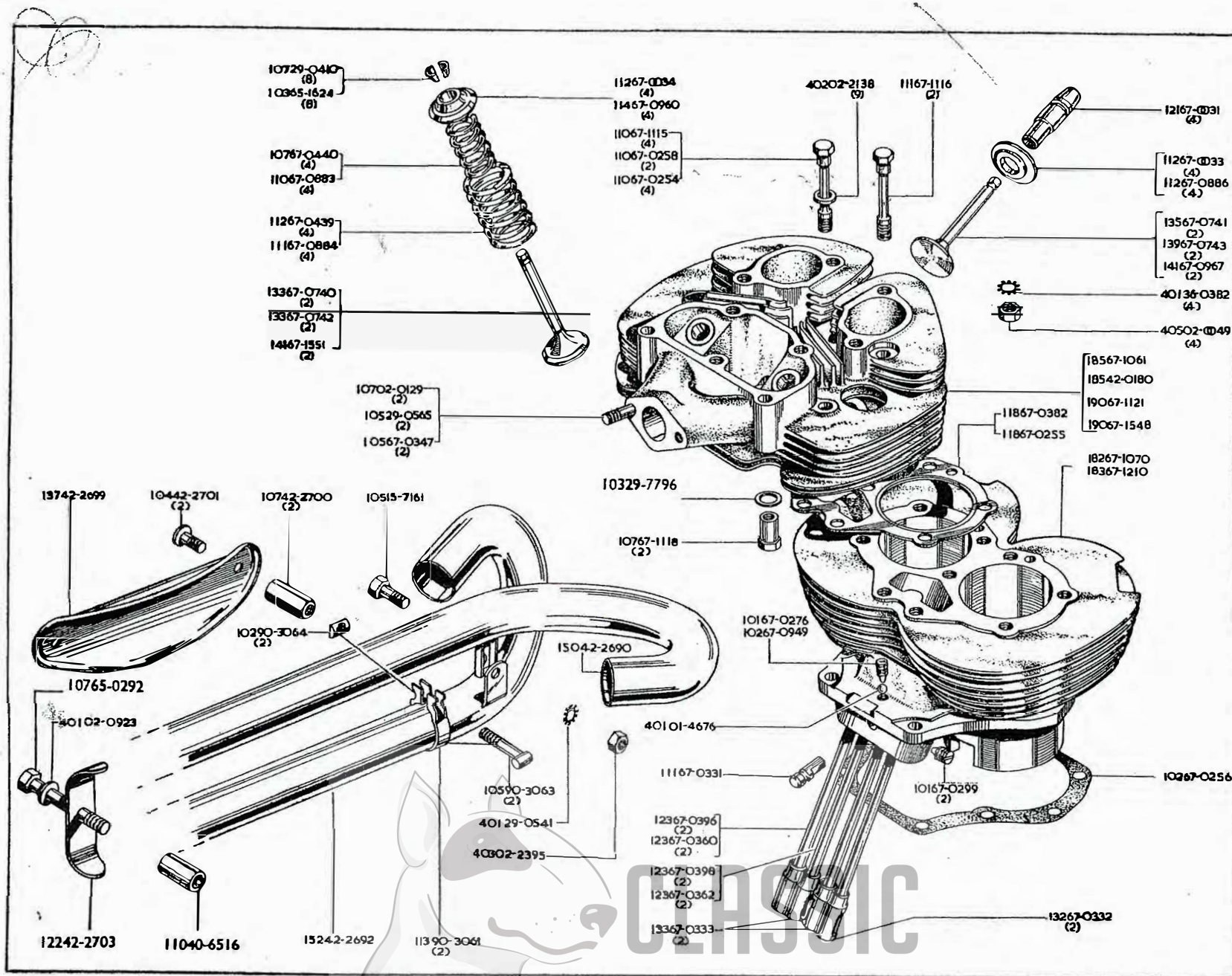

CLASSIC
 BIKE SPARES

**CYLINDER
CYLINDRE
ZYLINDER
CILINDRO**

**CYLINDER HEAD
CULASSE
ZYLINDERKOPF
CULATA**

Model Modèle Typen Modelos	Spare No. No. de pièce Ersatzteil-Nr. No. de repuesto	Description	Designation	Beschreibung	Descripción	Per Set Par jeu Pr. Satz Juego de
A10S/R ...	1 05 67-0347	Stud	Goujon	Stehbolzen	Esparago	2
A10, A10S/R ...	1 23 67-0360	Push Rod (inlet)	Tige de culbuter (d'admission)	Stößelstange (einlass)	Varilla (admisión)	2
A10, A10S/R ...	1 23 67-0362	Push Rod (exhaust)	Tige de culbuteuf (d'échappement)	Stößelstange (auslass)	Varilla (escape)	2
A7, A7S/S ...	1 18 67-0382	Gasket	Joint	Dichtung	Empaquetadura	
A7, A7S/S ...	1 23 67-0396	Push Rod (inlet)	Tige de culbuteur (d'admission)	Stößelstange (einlass)	Varilla (admisión)	2
A7, A7S/S ...	1 23 67-0398	Push Rod (exhaust)	Tige de culbuteur (d'échappement)	Stößelstange (auslass)	Varilla (escape)	2
A7, A7S/S, A10 ...	1 12 67-0439	Spring (outer)	Ressort (extérieur)	Feder (aussere)	Resorte (exterior)	4
A7, A7S/S, A10 ...	1 07 67-0440	Spring (inner)	Ressort (intérieur)	Feder (innen)	Resorte (interior)	4
A7, A7S/S ...	1 33 67-0740	Inlet Valve	Soupape d'admission	Einlassventil	Válvula de admisión	2
A7, A7S/S ...	1 35 67-0741	Exhaust Valve	Soupape d'échappement	Auslassventil	Válvula de escape	2
A10 ...	1 33 67-0742	Inlet Valve	Soupape d'admission	Einlassventil	Válvula de admisión	2
A10 ...	1 39 67-0743	Exhaust Valve	Soupape d'échappement	Auslassventil	Válvula de escape	2
A10S/R ...	1 10 67-0883	Spring (inner)	Ressort (intérieur)	Feder (innen)	Resorte (interior)	4
A10S/R ...	1 11 67-0884	Spring (outer)	Ressort (extérieur)	Feder (aussere)	Resorte (exterior)	4
A10S/R ...	1 12 67-0886	Spring Cup	Siege de ressort	Federhülse	Copa	4
A10, A10S/R ...	1 02 67-0949	Screw	Vis	Schraube	Tornillo	
A10S/R ...	1 14 67-0960	Collar	Bague d'arrêt	Stellring	Anillo móvil aprisionado	4
A10S/R ...	1 41 67-0967	Exhaust Valve	Soupape d'échappement	Auslassventil	Válvula de escape	2
A7 ...	1 85 67-1061	Cylinder Head	Culasse	Zylinderkopf	Culata	
A7, A7S/S ...	1 82 67-1070	Cylinder	Cylindre	Zylinder	Cilindro	
A7S/S, A10S/R ...	1 10 67-1115	Bolt	Boulon	Schraube	Tornillo	4
A7S/S, A10S/R ...	1 11 67-1116	Bolt	Boulon	Schraube	Tornillo	2
A7S/S, A10S/R ...	1 07 67-1118	Nut	Écrou	Mutter	Tuerca	2
A7S/S ...	1 90 67-1121	Cylinder Head	Culasse	Zylinderkopf	Culata	
A10, A10S/R ...	1 83 67-1210	Cylinder	Cylindre	Zylinder	Cilindro	
A10S/R ...	1 90 67-1548	Cylinder Head	Culasse	Zylinderkopf	Culata	
A10S/R ...	1 41 67-1551	Inlet Valve	Soupape d'admission	Einlassventil	Válvula de admisión	2
Spitfire Scrambler ...	1 13 90-3061	Clip complete	Bride complet	Klammer kompl.	Grapa completa	
Spitfire Scrambler ...	1 05 90-3063	Bolt	Boulon	Schraube	Tornillo	
Spitfire Scrambler ...	1 02 90-3064	Saddle Washer	Rondelle de selles	Sattelscheibe	Arandela para sillín	



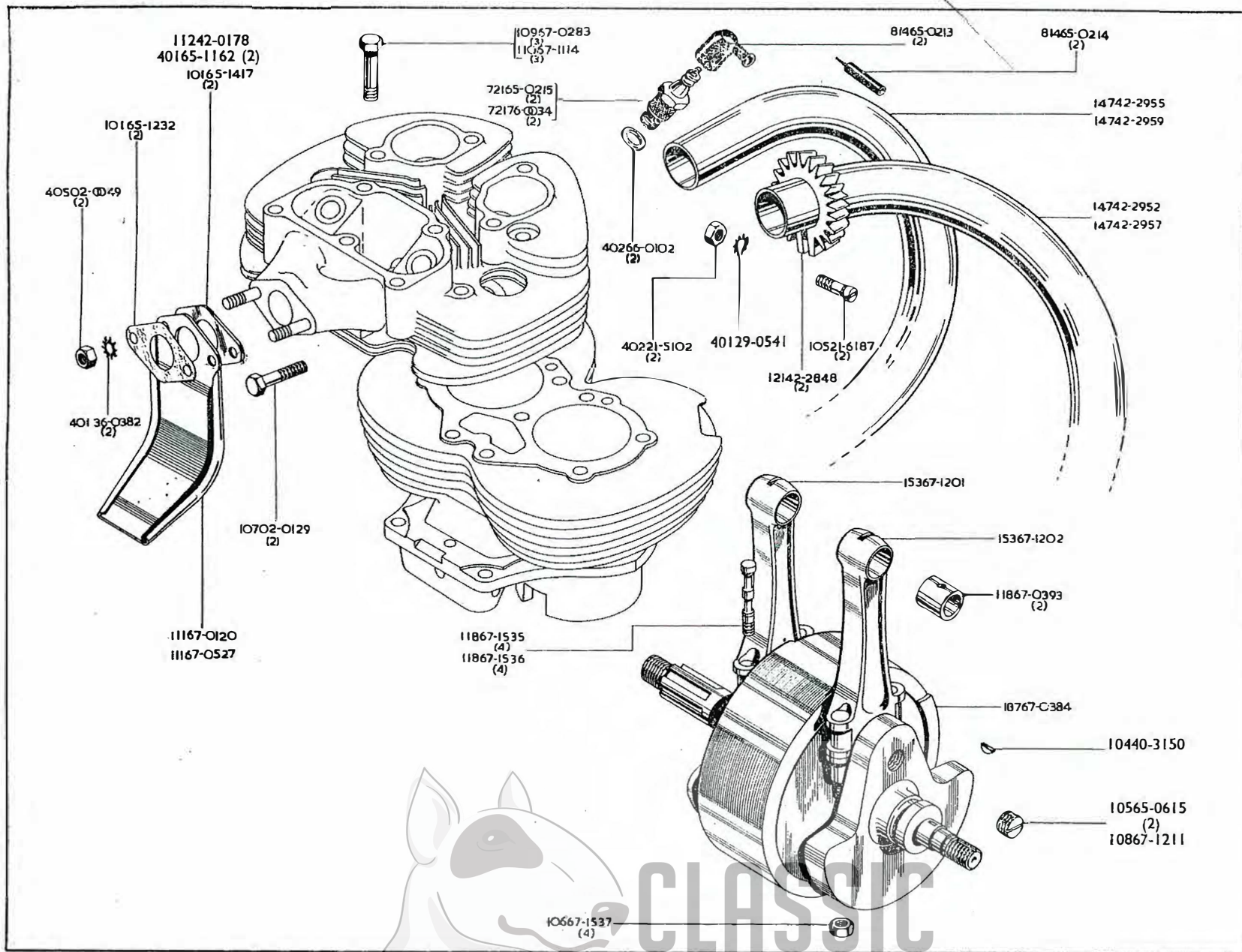

CLASSIC
 BIKE SPARES

**CRANKSHAFT
VILEBREQUIN
KURBELWELLE
CIGUENAL**

**EXHAUST PIPE
TUYAU D'ÉCHAPPEMENT
AUSPUFFROHR
TUBO DE ESCAPE**

Model Modèle Typen Modelos	Spares No. No. de pièce Ersatzteil-Nr. No. de repuesto	Description	Designation	Beschreibung	Descripción	Per Set Par jeu Pr. Satz Juego de
A7S/S, A10S/R ...	4 05 02-0049	Nut	Écrou	Mutter	Tuerca	2
A7, A10 ...	1 07 02-0129	Bolt	Boulon	Schraube	Tornillo	2
A Group ...	4 02 21-5102	Nut	Écrou	Mutter	Tuerca	2
A Group ...	1 05 21-6187	Screw	Vis	Schraube	Tornillo	2
A Group ...	4 01 29-0541	Lockwasher	Rondelle frein	Sicherungsscheibe	Freno	2
A7, A10 ...	4 01 36-0382	Lockwasher	Rondelle frein	Sicherungsscheibe	Freno	2
A Group ...	1 04 40-3150	Woodruff Key	Clavette Woodruff	Scheibenfeder	Chaveta Woodruff	2
A10S/R ...	1 12 42-0178	Gasket	Joint	Dichtung	Empaquetadura	
A Group ...	1 21 42-2848	Collar	Bague d'arrêt	Steltring	Anillo móvil aprisionado	
A7, A7S/S ...	1 47 42-2952	Exhaust Pipe (o/s)	Tuyau d'échappement (droite)	Auspuffrohr (rechts)	Tubo de escape (der.)	
A7, A7S/S ...	1 47 42-2955	Exhaust Pipe (n/s)	Tuyau d'échappement (gauche)	Auspuffrohr (links)	Tubo de escape (izq.)	
A10, A10S/R ...	1 47 42-2957	Exhaust Pipe (o/s)	Tuyau d'échappement (droite)	Auspuffrohr (rechts)	Tubo de escape (der.)	
A10, A10S/R ...	1 47 42-2959	Exhaust Pipe (n/s)	Tuyau d'échappement (gauche)	Auspuffrohr (links)	Tubo de escape (izq.)	
A Group ...	8 14 65-0213	IG. Lead Terminal	Borne de cable d'allumage	Zündleitungstecker	Borne de conexión	2
A Group ...	8 14 65-0214	Suppressor	Dispositif antiparasite	Entstoerter Kabelschuh	Supresor	2
A7S/S, A10S/R ...	7 21 65-0215	Spark Plug	Bougie d'allumage	Zündkerze	Bujía	
A7, A7S/S ...	1 05 65-0615	Plug	Bouchon	Stopfen	Tapon	2
A7 ...	4 01 65-1162	Gasket	Joint	Dichtung	Empaquetadura	2
A7S/S, A10 ...	1 01 65-1232	Gasket	Joint	Dichtung	Empaquetadura	2
A10S/R ...	1 01 65-1417	Gasket	Joint	Dichtung	Empaquetadura	2
A Group ...	4 02 66-0102	Sealing Washer	Joint	Dichtung	Arandela de reten	2
A7, A10 ...	1 11 67-0120	Drip Shield	Garde-gonttes	Tropfschutzblech	Guardagotas	
A7, A10 ...	1 09 67-0283	Bolt	Boulon	Schraube	Tornillo	3
A7, A7S/S ...	1 87 67-0384	Crankshaft complete	Vilebrequin complet	Kurbelwelle kompl.	Ciguñal completa	
A7, A7S/S ...	1 18 67-0393	Bush	Donille	Büchse	Casquillo	2
A7S/S, A10S/R ...	1 11 67-0527	Drip Shield	Garde-gonttes	Tropfschutzblech	Guardagotas	
A7S/S, A10S/R ...	1 10 67-1114	Bolt	Boulon	Schraube	Tornillo	3
A7, A7S/S ...	1 53 67-1201	Connecting Rod (left-hand)	Bielle (gauche)	Pluelstange (links)	Varilla de acoplamiento (izq.)	
A7, A7S/S ...	1 53 67-1202	Connecting Rod (right-hand)	Bielle (droite)	Pluelstange (rechts)	Varilla de acoplamiento (der.)	
A10, A10S/R ...	1 08 67-1211	Plug	Bouchon	Stopfen	Tapon	2
A7, A7S/S ...	1 18 67-1535	Bolt	Boulon	Schraube	Tornillo	4
A10, A10S/R ...	1 18 67-1536	Bolt	Boulon	Schraube	Tornillo	4
A Group ...	1 06 67-1537	Nut	Écrou	Mutter	Tuerca	4
A7, A10 ...	7 21 76-0034	Spark Plug	Bougie d'allumage	Zündkerze	Bujía	2



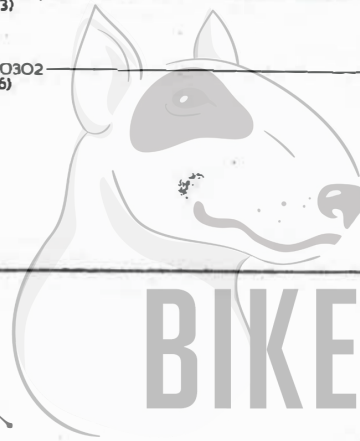
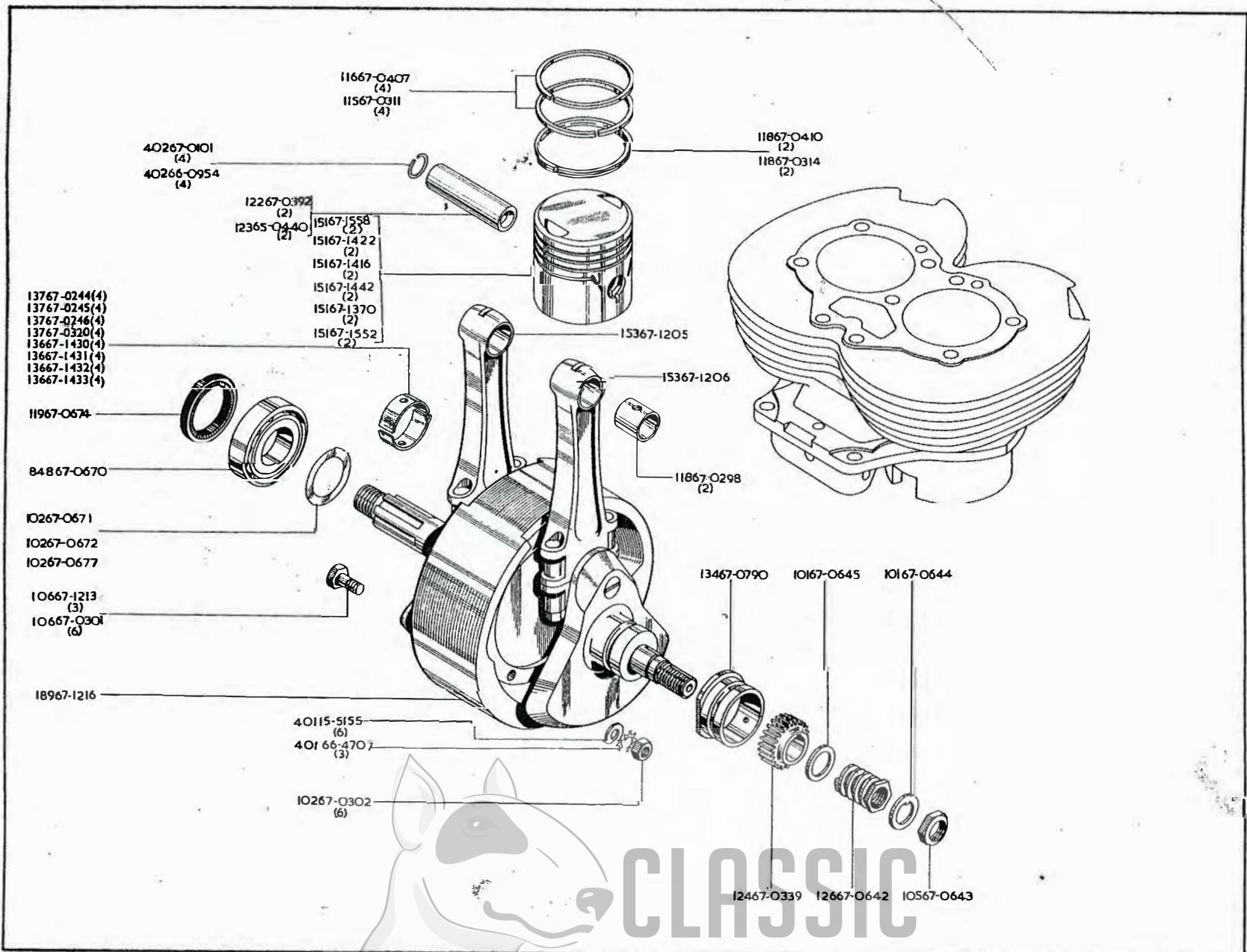

CLASSIC
 BIKE SPARES

**CRANKSHAFT
VILEBREQUIN
KURBELWELLE
CIGUENAL**

**PISTON
PISTON
KOLBEN
EMBOLO**

Model Modèle Typen Modelos	Spares No. No de pièce Ersatzteil-Nr. No. de repuesto	Description	Designation	Beschreibung	Descripción	Per Set Par jeu Pr. Satz Juego de
A7, A7S/S ...	4 01 15-5155	Washer	Rondelle	Scheibe	Arandela	6
A10, A10S/R ...	1 23 65-0440	Gudgeon Pin	Axe de piston	Kolbenbolzen	Bulón de embolo	2
A10, A10S/R ...	4 02 66-0954	Circlip	Arrêtoir	Sprengring	Freno	4
A10, A10S/R ...	4 01 66-4707	Lockwasher	Rondelle frein	Sicherungsscheibe	Freno	3
A7, A7S/S ...	4 02 67-0101	Circlip	Arrêtoir	Sprengring	Freno	4
A7, A7S/S ...	1 37 67-0244	Bearing Shell (— .010 in.)	Coquille de palier (— .254 mm.)	Lager (— .254 mm.)	Chumacera (— .254 mm.)	4
A7, A7S/S ...	1 37 67-0245	Bearing Shell (— .020 in.)	Coquille de palier (— .508 mm.)	Lager (— .508 mm.)	Chumacera (— .508 mm.)	4
A7, A7S/S ...	1 38 67-0246	Bearing Shell (— .030 in.)	Coquille de palier (— .762 mm.)	Lager (— .762 mm.)	Chumacera (— .762 mm.)	4
A10, A10S/R ...	1 18 67-0298	Bush	Douille	Büchse	Casquill	2
A7, A7S/S ...	1 06 67-0301	Bolt	Boulon	Schraube	Tornillo	6
A7, A7S/S ...	1 02 67-0302	Nut	Écrou	Mutter	Tuerca	6
A10, A10S/R ...	1 15 67-0311	Piston Ring	Segment	Kolbenring	Segmento	4
A10, A10S/R ...	1 18 67-0314	Piston Ring	Segment	Kolbenring	Segmento	2
A7, A7S/S ...	1 37 67-0320	Bearing Shell	Coquille de palier	Lager	Chumacera	4
A Group ...	1 24 67-0339	Pinion	Pignon	Ritzel	Piñón	
A7, A7S/S ...	1 22 67-0392	Gudgeon Pin	Axe de piston	Kolbenbolzen	Bulón de embolo	2
A7, A7S/S ...	1 16 67-0407	Piston Ring	Segment	Kolbenring	Segmento	4
A7, A7S/S ...	1 18 67-0410	Piston Ring	Segment	Kolbenring	Segmento	2
A Group ...	1 26 67-0642	Pinion	Pignon	Ritzel	Piñón	
A Group ...	1 05 67-0643	Nut	Écrou	Mutter	Tuerca	
A Group ...	1 01 67-0644	Lockwasher	Rondelle frein	Sicherungsscheibe	Freno	
A Group ...	1 01 67-0645	Washer	Rondelle	Scheibe	Arandela	
A Group ...	8 48 67-0670	Bearing	Roulement	Lager	Rolamiento	
A Group ...	1 02 67-0671	Distance Piece (.005 in.)	Entretoise (.127 mm.)	Distanzrohr (.127 mm.)	Distanciadador (.127 mm.)	
A Group ...	1 02 67-0672	Distance Piece (.010 in.)	Entretoise (.254 mm.)	Distanzrohr (.254 mm.)	Distanciadador (.254 mm.)	
A Group ...	1 19 67-0674	Oil Seal	Joint d'huile	Simmering	Reten de aceite	
A Group ...	1 02 67-0677	Distance Piece (.033 in.)	Entretoise (.0762 mm.)	Distanzrohr (.0762 mm.)	Distanciadador (.0762 mm.)	
A Group ...	1 34 67-0790	Bush	Douille	Büchse	Casquillo	
A Group ...	1 34 67-0799	Bush (— .010 in.)	Douille (— .254 mm.)	Büchse (— .254 mm.)	Casquillo (— .254 mm.)	
A10, A10S/R ...	1 53 67-1205	Connecting Rod (left-hand)	Bielle (gauche)	Pleuelstange (links)	Varilla de acoplamiento (izq.)	
A10, A10S/R ...	1 53 67-1206	Connecting Rod (right-hand)	Bielle (droite)	Pleuelstange (rechts)	Varilla de acoplamiento (der.)	
A10, A10S/R ...	1 06 67-1213	Bolt	Boulon	Schraube	Tornillo	3
A10, A10S/R ...	1 89 67-1216	Crankshaft complete	Vilebrequin complet	Kurbelwelle kompl.	Ciguñal completa	
A10S/R ...	1 51 67-1370	Piston complete (8.26—1)	Piston complet (8.26—1)	Kolben kompl. (8.26—1)	Embolo completa (8.26—1)	2
Royal Tourist	1 51 67-1370*	Piston complete (8.3—1)	Piston complet (8.3—1)	Kolben kompl. (8.3—1)	Embolo completa (8.3—1)	2
A10 ...	1 51 67-1416	Piston complete (7.25—1)	Piston complet (7.25—1)	Kolben kompl. (7.25—1)	Embolo completa (7.25—1)	2
A7 ...	1 51 67-1422	Piston complete (7.25—1)	Piston complet (7.25—1)	Kolben kompl. (7.25—1)	Embolo completa (7.25—1)	2
A10, A10S/R ...	1 36 67-1430	Bearing Shell	Coquille de palier	Lager	Chumacera	4
A10, A10S/R ...	1 36 67-1431	Bearing Shell (— .010 in.)	Coquille de palier (— .254 mm.)	Lager (— .254 mm.)	Chumacera (— .254 mm.)	4
A10, A10S/R ...	1 36 67-1432	Bearing Shell (— .020 in.)	Coquille de palier (— .508 mm.)	Lager (— .508 mm.)	Chumacera (— .508 mm.)	4
A10, A10S/R ...	1 36 67-1433	Bearing Shell (— .030 in.)	Coquille de palier (— .762 mm.)	Lager (— .762 mm.)	Chumacera (— .762 mm.)	4
A7S/S ...	1 51 67-1442	Piston complete (8.25—1)	Piston complet (8.25—1)	Kolben kompl. (8.25—1)	Embolo completa (8.25—1)	2
500 Flash	1 51 67-1442*	Piston complete (8—1)	Piston complet (8—1)	Kolben kompl. (8—1)	Embolo completa (8—1)	2
Spitfire Scrambler S/R	1 51 67-1552*	Piston complete (8.75—1)	Piston complet (8.75—1)	Kolben kompl. (8.75—1)	Embolo completa (8.75—1)	2
A7S/S ...	1 51 67-1558*	Piston complete (8.5—1)	Piston complet (8.5—1)	Kolben kompl. (8.5—1)	Embolo completa (8.5—1)	2

*American type.

*Type American.

*Amerikanische Typen.

*Tipo Americano.

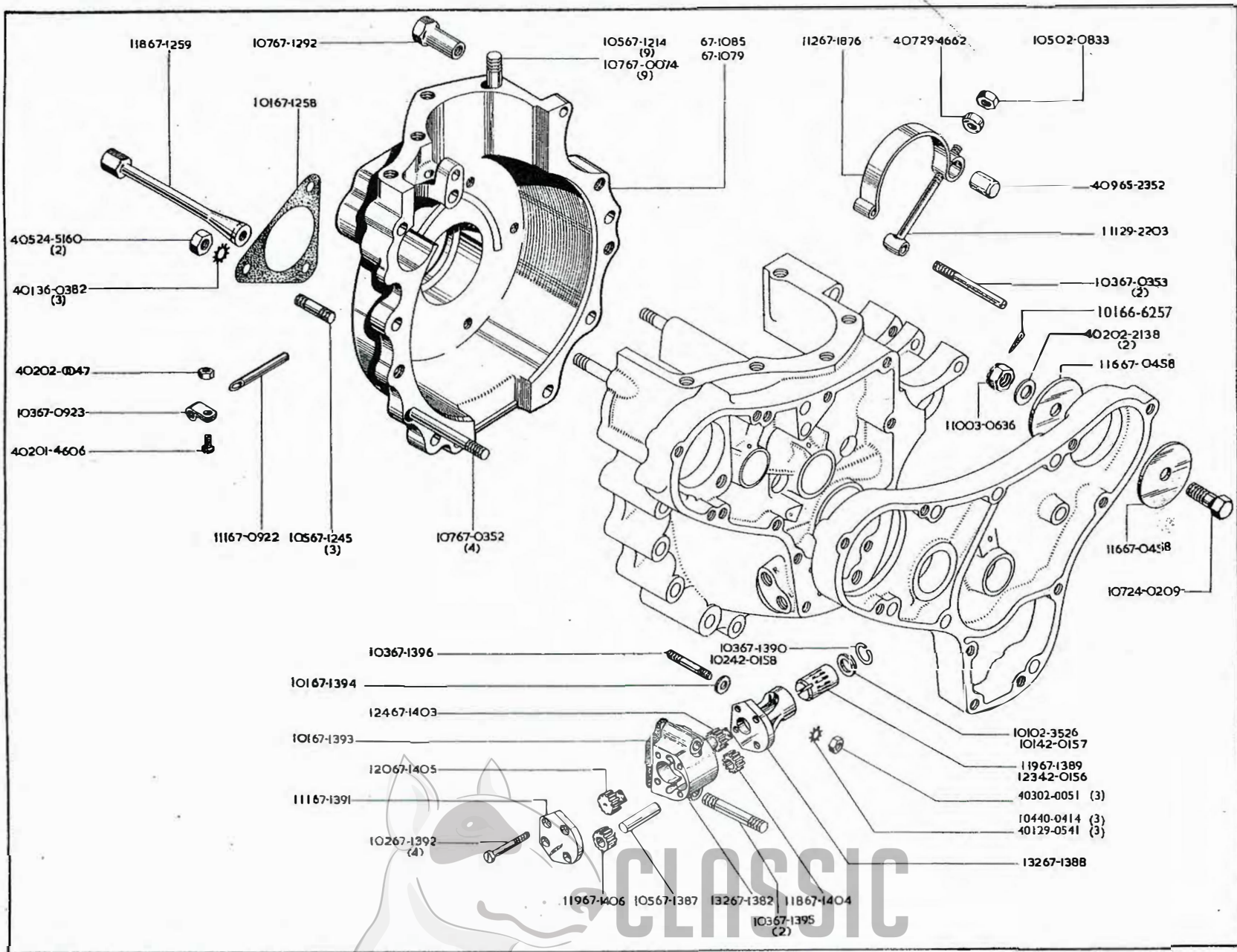

CLASSIC
BIKE SPARES

**CRANKCASE
CARTER DE VILBREQUIN
KURBELGEHÄUSE
CAJA DE CIGUENAL**

**OIL PUMP
POMPE À HUILE
ÖLPUMPE
BOMBA DE ACEITE**

Model Modèle Typen Modelos	Spares No. No. de pièce Ersatzteil-Nr. No. de repuesto	Description	Designation	Beschreibung	Descripción	Per Set Par jeu Pr. Satz Juego de
A Group	4 02 01-4606	Screw	Vis	Schraube	Tornillo	
A Group	4 02 02-0047	Nut	Écrou	Mutter	Tuerca	
A Group	4 03 02-0051	Nut	Écrou	Mutter	Tuerca	3
A Group	1 05 02-0833	Nut	Écrou	Mutter	Tuerca	
Spitfire Scrambler	4 02 02-2138	Washer	Rondelle	Scheibe	Arandela	2
A Group	1 01 02-3526	Washer	Rondelle	Scheibe	Arandela	
Spitfire Scrambler	1 10 03-0636	Nut	Écrou	Mutter	Tuerca	
Spitfire Scrambler	1 07 24-0209	Bolt	Boulon	Schraube	Tornillo	
A Group	4 05 24-5160	Nut	Écrou	Mutter	Tuerca	2
A Group	4 01 29-0541	Lockwasher	Rondelle frein	Sicherungsscheibe	Freno	3
A Group	1 11 29-2203	Bolt	Boulon	Schraube	Tornillo	
A Group	4 07 29-4662	Washer	Rondelle	Scheibe	Arandela	
A Group	4 01 36-0382	Lockwasher	Rondelle frein	Sicherungsscheibe	Freno	3
A10S/R	1 23 42-0156	Spindle	Arbre	Welle	Arbol	
A10S/R	1 01 42-0157	Washer	Rondelle	Scheibe	Arandela	
A10S/R	1 02 42-0158	Circlip	Arrêtoir	Sicherung	Freno	
A Group	4 09 65-2352	Plug	Bouchon	Stopfen	Tapon	
Spitfire Scrambler	1 01 66-6257	Split Pin	Goupille fendue	Splint	Chaveta hendida	
A7, A7S/S	1 05 67-0074	Stud	Goujon	Stehbolzen	Esparago	9
A Group	1 07 67-0352	Stud	Goujon	Stehbolzen	Esparago	4
A Group	1 03 67-0353	Stud	Goujon	Stehbolzen	Esparago	2
Spitfire Scrambler	1 16 67-0458	Cover Plate	Plaque couvercle	Abdeckplatte	Tapa del cojinete	2
A Group	1 11 67-0922	Breather	Reniflard	Entlüfter	Respirador	
A Group	1 03 67-0923	Clip	Bride	Klammer	Grapa	
A10, A10S/R	67-1079*	Crankcase (left-hand)	Carter de vilebrequin (gauche)	Kurbelgehäuse (links)	Caja de cigüeñal (izq.)	
A7, A7S/S	67-1085*	Crankcase (left-hand)	Carter de vilebrequin (gauche)	Kurbelgehäuse (links)	Caja de cigüeñal (izq.)	
A10, A10S/R	1 05 67-1214	Stud	Goujon	Stehbolzen	Esparago	9
		*Supplied only as Crankcase complete.	*Livres seulement comme carter complet.	*Nur Als komplettes Gehäuse Lieferbar.	*Suministrados solamente como carter completa.	
		A7, A7S/S 1 88 67-1089	A7, A7S/S 1 88 67-1089	A7, A7S/S 1 88 67-1089	A7, A7S/S 1 88 67-1089	
		A10, A10S/R 1 88 67-1077	A10, A10S/R 1 88 67-1077	A10, A10S/R 1 88 67-1077	A10, A10S/R 1 88 67-1077	

**CLASSIC
BIKE SPARES**

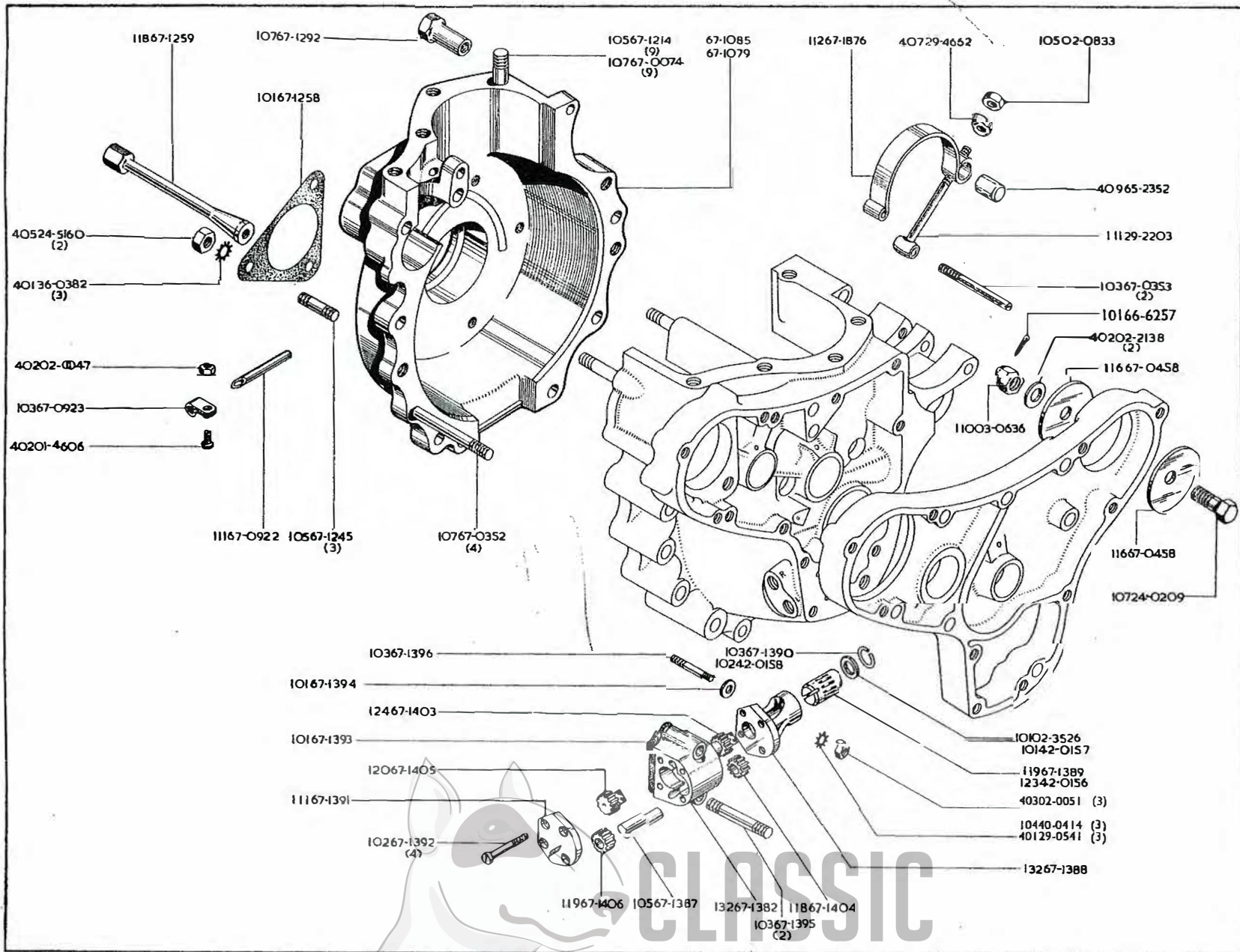

CLASSIC
 24
 BIKE SPARES

**CRANKCASE
CARTER DE VILBREQUIN
KURBELGEHÄUSE
CAJA DE CIGUENAL**

**OIL PUMP
POMPE À HUILE
ÖLPUMPE
BOMBA DE ACEITE**

Model Modèle Typen Modelos	Spares No. No. de pièce Ersatzteil-Nr. No. de repuesto	Description	Designation	Beschreibung	Descripción	Per Set Par jeu Pr. Satz Juego de
A Group	1 05 67-1245	Stud	Goujon	Stehbolzen	Esparago	3
A Group	1 01 67-1258	Gasket	Joint	Dichtung	Empaquetadura	
A Group	1 18 67-1259	Nut (long)	Écrou (longue)	Mutter (Lang)	Tuerca (largo)	
A Group	1 07 67-1292	Nut (top)	Écrou (supérieur)	Mutter (Oben)	Tuerca (superior)	
A Group	1 32 67-1382	Oil Pump Body	Corps du pompe à huile	Ölpumpengehäuse	Cuerpo de la bomba de aceite	
A Group	1 05 67-1387	Spindle	Arbre	Welle	Arbol	
A Group	1 32 67-1388	Spindle Housing	Logement de l'axe	Spindelgehäuse	Envoltura del eje	
A7, A7S/S, A10	1 19 67-1389	Spindle	Arbre	Welle	Arbol	
A Group	1 03 67-1390	Circlip	Arrêtoir	Sprengring	Freno	
A Group	1 11 67-1391	Bottom Cover	Chapeau de protection (inf.)	Schutzkappe (unten)	Tapa (inferior)	
A Group	1 02 67-1392	Screw	Vis	Schraube	Tornillo	4
A Group	1 01 67-1393	Gasket	Joint	Dichtung	Empaquetadura	
A Group	1 01 67-1394	Washer	Rondelle	Scheibe	Arandela	
A Group	1 03 67-1395	Stud (long)	Goujon (longue)	Stehbolzen (lang)	Esparago (largo)	2
A Group	1 03 67-1396	Stud (short)	Goujon (courte)	Stehbolzen (kurz)	Esparago (corte)	
A Group	1 24 67-1403	Feed Gear (driver)	Commande de l'engrenage d'augmentation.	Zufuhrzahnradantrieb	Impulsador del engranaje	
A Group	1 18 67-1404	Feed Gear	Engrenage d'augmentation	Zufuhrzahnrad	Engranaje de aumentación	
A Group	1 20 67-1405	Scavenge Gear (driver)	Engrenage d'entraînement	Antriebsrad	Engranaje de mando	
A Group	1 19 67-1406	Scavenge Gear (driven)	Engrenage entraîné	Getriebenes Zahnrad	Engranaje impulsado	
A Group	1 12 67-1876	Dynamo Strap	Bande de fixation du dynamo	Haltebügel für Lichtmaschine	Cinta de fijación del dinamo	

1 04 40-0414(3) Oil Pump
Fixing Nut fitted on and
after Engine No.

Model A7 — 8751
Model A7S/S — 8114
Model A10 — 13388
Model A10 S/Scrambler 3229

1 04 40-0414(3) Ecrou pour pompe
à huile montée depuis moteur
numéro

Model A7 — 8751
Model A7S/S — 8114
Model A10 — 13388
Model A10 S/Scrambler 3229

1 04 40-0414(3) Mutter für
Ölpumpe Nach Motornummer
Montiert

Model A7 — 8751
Model A7S/S — 8114
Model A10 — 13388
Model A10 S/Scrambler 3229

1 04 40-0414(3) Tuerca para bomba de
aceite montada después de motor
numero

Model A7 — 8751
Model A7S/S — 8114
Model A10 — 13388
Model A10 S/Scrambler 3229

CLASSIC
BIKE SPARES

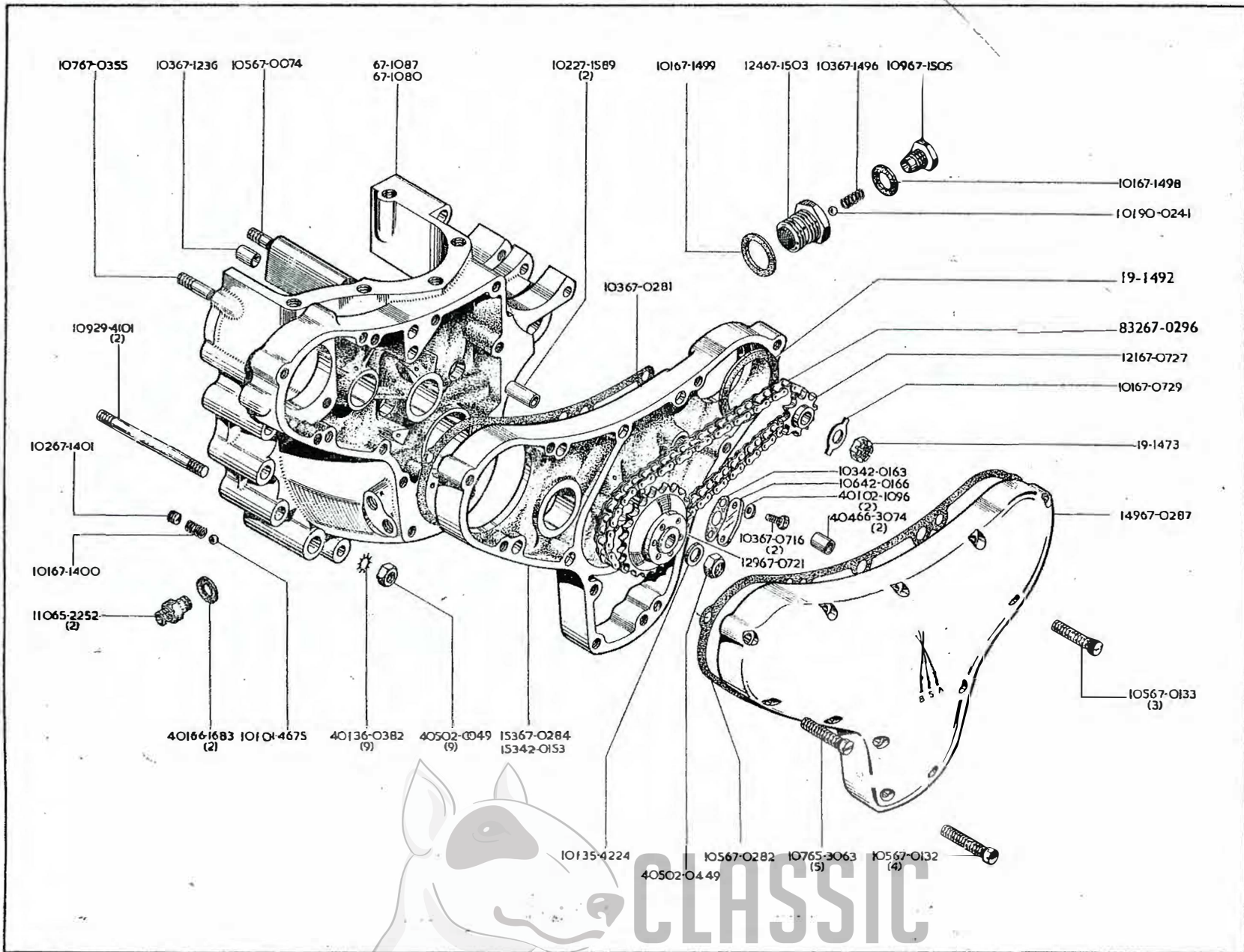

CLASSIC BIKE SPARES

**CRANKCASE
CARTER DE VILEBREQUIN
KURBELGEHÄUSE
CAJA DE CIGUENAL**

**INNER COVER
COUVERCLE INTÉRIEUR
INNERE SCHUTZKAPPE
TAPA INTERIOR**

**OUTER COVER
COUVERCLE EXTÉRIEUR
AUSSEN SCHUTZKAPPE
TAPA EXTERIOR**

Model Modèle Typen Modelos	Spares No. No. de pièce Ersatzteil-Nr. No. de repuesto	Description	Designation	Beschreibung	Descripción	Per Set Par jeu Pr. Satz Juego de
A Group	1 01 01-4675	Ball	Bille	Kugel	Bola	
A Group	4 05 02-0049	Nut	Écrou	Mutter	Tuerca	9
A Group	4 05 02-0449	Nut	Écrou	Mutter	Tuerca	
A7, A7S/S A10	4 01 02-1096	Washer	Rondelle	Scheibe	Arandela	
A Group	19-1429	Gasket	Joint	Dichtung	Empaquetadura	
A Group	19-1473	Nut	Écrou	Mutter	Tuerca	
A Group	1 02 27-1589	Dowel	Goupille	Stift	Pasador	2
A Group	1 09 29-4101	Stud	Goujon	Stehbolzen	Esparago	2
A Group	1 01 35-4224	Washer	Rondelle	Scheibe	Arandela	
A Group	4 01 36-0382	Lockwasher	Rondelle frein	Sicherungsscheibe	Freno	9
A10S/R	1 53 42-0153	Inner Cover	Couvercle intérieur	Innere Schutzkappe	Tapa (interior)	
A7, A7S/S, A10	1 03 42-0163	Gasket	Joint	Dichtung	Empaquetadura	
A7, A7S/S, A10	1 06 42-0166	Cover Plate	Plaque couvercle	Abdeckplatte	Tapa del cojinete	
A Group	1 10 65-2252	Adaptor	Pièce d'ajustement	Anschlussrohr	Tubo de ajuste	2
A Group	1 07 65-3063	Screw	Vis	Schraube	Fornillo	5
A Group	4 01 66-1683	Oil Seal	Joint d'huile	Simmerring	Reten de aceite	2
A Group	4 04 66-3074	Dowel	Goupille	Passtift	Pasador	2
A Group	1 05 67-0074	Stud	Goujon	Stehbolzen	Esparago	
A Group	1 05 67-0132	Screw (long)	Vis (longue)	Schraube (Lang)	Tornillo (largo)	4
A Group	1 05 67-0133	Screw	Vis	Schraube	Tornillo	3
A Group	1 03 67-0281	Gasket	Joint	Dichtung	Empaquetadura	
A Group	1 05 67-0282	Gasket	Joint	Dichtung	Empaquetadura	
A Group	1 53 67-0284	Inner Cover	Couvercle intérieur	Innere Schutzkappe	Tapa (interior)	
A7, A7S/S, A10	1 49 67-0287	Outer Cover	Couvercle extérieur	Aussen Schutzkappe	Tapa (exterior)	
A Group	8 32 67-0296	Chain	Chaîne	Kette	Cadena	
A Group	1 07 67-0355	Stud	Goujon	Stehbolzen	Esparago	
A7, A7S/S, A10	1 03 67-0716	Bolt	Boulon	Schraube	Tornillo	2
A7, A10	1 29 67-0721	Sprocket	Pignon	Ritzel	Piñón	
A Group	1 21 67-0727	Sprocket (11T)	Pignon D-11	Ritzel Z-11	Piñón D-11	
A Group	1 01 67-0729	Lockwasher	Rondelle frein	Sicherung	Freno	
A10, A10S/R	67-1080*	Crankcase (right-hand)	Carter de vilebrequin (droite)	Kurbelgehäuse (rechts)	Caja de cigüeñal (der.)	
A7, A7S/S	67-1087*	Crankcase (right-hand)	Carter de vilebrequin (droite)	Kurbelgehäuse (rechts)	Caja de cigüeñal (der.)	
A Group	1 03 67-1236	Dowel	Goupille cylindrique	Stift	Pasador	
A Group	1 01 67-1400	Spring	Ressort	Feder	Resorte	
A Group	1 02 67-1401	Screw	Vis	Schraube	Tornillo	
A Group	1 03 67-1496	Spring	Ressort	Feder	Resorte	
A Group	1 01 67-1498	Sealing Washer	Joint	Dichtung	Arandela de reten	
A Group	1 01 67-1499	Sealing Washer	Joint	Dichtung	Arandela de reten	
A Group	1 24 67-1503	Release Valve	Soupape de décharge	Überdruck Ventil	Válvula despresadora	
A Group	1 09 67-1505	Plug	Bouchon	Stopfen	Tapon	
A Group	1 01 90-0241	Ball	Bille	Kugel	Bola	

*Supplied only as Crankcase complete.
A7, A7S/S 67-1089.
A10, A10S/R 67-1077.

*Livres seulement comme carter complet.
A7, A7S/S 67-1089.
A10, A10S/R 67-1077.

*Nur Als komplett Gehäuse Lieferbar
A7, A7S/S 67-1089.
A10, A10S/R 67-1077.

*Suministrads solamente como carter completa.
A7, A7S/S 67-1089.
A10, A10S/R 67-1077.

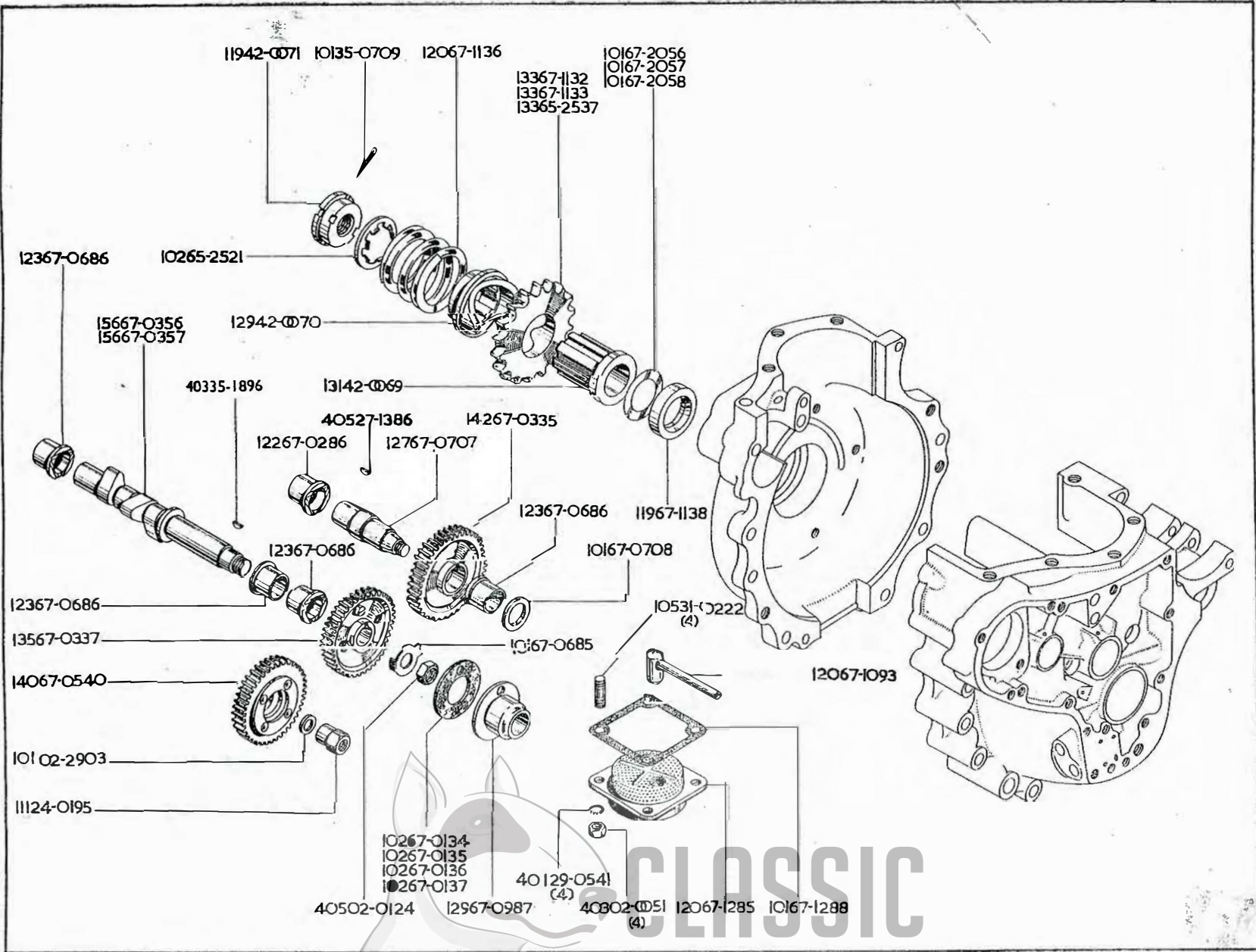

CLASSIC
 BIKE SPARES

**CUSH DRIVE
TRANSMISSION AMORTIE
PUFFERANTRIEB
MANDO AMORTIGUADO**

**CAMSHAFT
ARBRE DE CAMES
NOCKENWELLE
ARBOL DE LEVAS**

Model Modèle Typen Modelos	Spares No. No. de pièce Ersatzteil-Nr. No. de repuesto	Description	Designation	Beschreibung	Descripción	Per Set Par jeu Pr. Satz Juego de
A Group	4 03 02-0051	Nut	Écrou	Mutter	Tuerca	4
A Group	4 05 02-0124	Nut	Écrou	Mutter	Tuerca	
A7S/S, A10S/R	1 01 02-2903	Washer	Rondelle	Scheibe	Arandela	
A7S/S, A10S/R	1 11 24-0195	Nut	Écrou	Mutter	Tuerca	
A Group	4 05 27-1386	Woodruff Key	Clavette	Rundkeil	Chaveta, Woodruff	
A Group	4 01 29-0541	Lockwasher	Rondelle frein	Sicherungsscheibe	Freno	4
A Group	1 05 31-0222	Stud	Goujon	Stehbolzen	Esparago	4
A Group	1 01 35-0709	Split Pin	Goupille fendue	Splint	Chaveta hendida	
A Group	4 03 35-1896	Woodruff Key	Clavette	Rundkeil	Chaveta Woodruff	
A Group	1 31 42-0069	Bearing	Roulement	Lager	Rolamiento	
A Group	1 29 42-0070	Sleeve	Douille	Büchse	Casquillo	
A Group	1 19 42-0071	Nut	Écrou	Mutter	Tuerca	
A Group	1 02 65-2521	Lockwasher	Rondelle frein	Sicherungsscheibe	Freno	
Spitfire Scrambler	1 33 65-2537	Sprocket (17T)	Pignon D-17	Ritzel Z-17	Piñón D-17	
A Group	1 02 67-0134	Sealing Washer	Joint d'étanchéité	Dichtung	Arandela de reten	
A Group	1 02 67-0135	Sealing Washer	Joint d'étanchéité	Dichtung	Arandela de reten	
A Group	1 02 67-0136	Sealing Washer	Joint d'étanchéité	Dichtung	Arandela de reten	
A Group	1 02 67-0137	Sealing Washer	Joint d'étanchéité	Dichtung	Arandela de reten	
A Group	1 22 67-0286	Bush	Douille	Büchse	Casquillo	
A Group	1 42 67-0335	Pinion complete	Pignon complet	Ritzel kompl.	Piñón completa	
A Group	1 35 67-0337	Pinion complete	Pignon complet	Ritzel kompl.	Piñón completa	
A Group	1 56 67-0356	Camshaft	Arbre de cames	Nockenwelle	Arbol de levas	
Spitfire Scrambler S/R	1 56 67-0357	Camshaft	Arbre de cames	Nockenwelle	Arbol de levas	
A7S/S, A10S/R	1 40 67-0540	Pinion complete	Pignon complet	Ritzel kompl.	Piñón completa	
A Group	1 01 67-0685	Lockwasher	Rondelle frein	Sicherungsscheibe	Freno	
A Group	1 23 67-0686	Bush	Douille	Büchse	Casquillo	4
A Group	1 27 67-0707	Spindle	Arbre	Welle	Arbol	
A Group	1 01 67-0708	Oil Seal	Joint d'huile	Simmerring	Reten de aceite	
A Group	1 29 67-0987	Breather	Reniflard	Enluffer	Respirador	
A Group	1 20 67-1093	Scavenge Pipe	Tuyaux à huile	Ölrohr	Tubo de aceite	
A7, A7S/S	1 33 67-1132	Sprocket (18T)	Pignon D-18	Ritzel Z-18	Piñón-D18	
A10S/car, A10S/R S/car	1 33 67-1132	Sprocket (18T)	Pignon D-18	Ritzel Z-18	Piñón D-18	
A10 Solo, A10S/R Solo	1 33 67-1133	Sprocket (21T)	Pignon D-21	Ritzel Z-11	Piñón D-21	
A Group	1 20 67-1136	Spring	Ressort	Feder	Resorte	
A Group	1 19 67-1138	Distance Piece	Entretoise	Distanzrohr	Distanciador	
A Group	1 20 67-1285	Cover	Couvercle	Schutzkappe	Tapa	
A Group	1 01 67-1288	Gasket	Joint	Dichtung	Empaquetadura	
A Group	1 01 67-2056	Shim (.005 in.)	Rondelle d'épaisseur (.127 mm.)	Ausgleichsscheibe (.127 mm.)	Espesor (.127 mm.)	
A Group	1 01 67-2057	Shim (.010 in.)	Rondelle d'épaisseur (.254 mm.)	Ausgleichsscheibe (.254 mm.)	Espesor (.254 mm.)	
A Group	1 01 67-2058	Shim (.030 in.)	Rondelle d'épaisseur (.762 mm.)	Ausgleichsscheibe (.762 mm.)	Espesor (.762 mm.)	
	Solo S/car.		Solo Sidecar	Solo Beiwagen	Solo Sidecar	

CLASSIC
BIKE SPARES

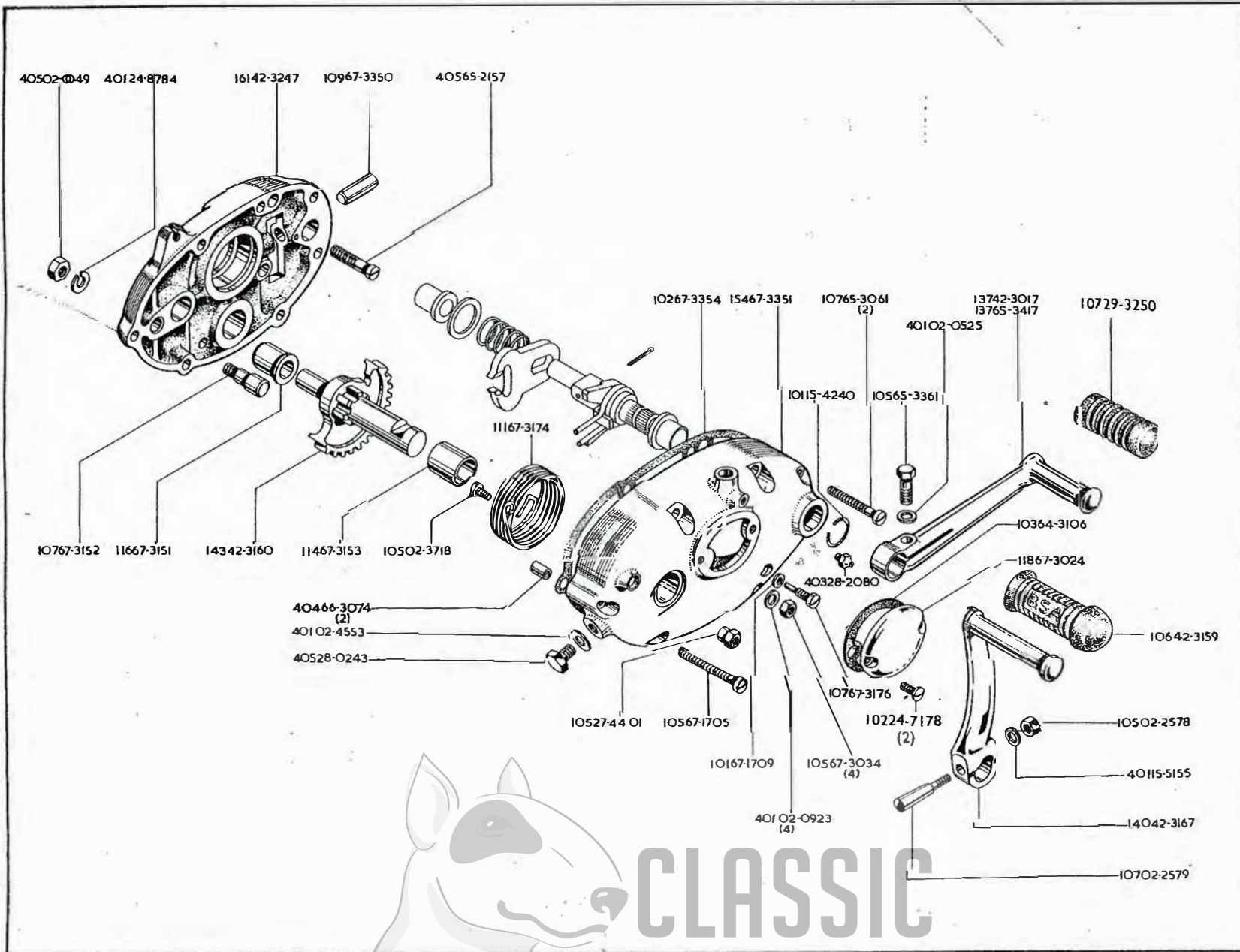

CLASSIC
BIKE SPARES

**FOOTSTART AND FOOTCHANGE
KICK-START ET SELECTEUR AU PIED
KICKSTART UND FUSSSCHALTUNG
ARRANCADOR Y CAMBIO DE PIES**

Model Modèle Typen Modelos	Spares No. No. de pièce Ersatzteil-Nr. No. de repuesto	Description	Designation	Beschreibung	Descripción	Per Set Par jeu Pr. Satz Juego de
A Group	... 4 05 02-0049	Nut	Écrou	Mutter	Tuerca	
A Group	... 4 01 02-0525	Washer	Rondelle	Scheibe	Arandela	
A Group	... 4 01 02-0923	Washer	Rondelle	Scheibe	Arandela	4
A Group	... 1 05 02-2578	Nut	Écrou	Mutter	Tuerca	
A Group	... 1 07 02-2579	Cotter	Demi-lune	Sicherungsstift	Chaveta ordinaria	
A Group	... 1 05 02-3718	Screw	Vis	Schraube	Tornillo	
A Group	... 4 01 02-4553	Sealing Washer	Joint	Dichtung	Arandela de reten	
A Group	... 1 01 15-4240	Circlip	Arrêtoir	Sprengring	Freno	
A Group	... 4 01 15-5155	Washer	Rondelle	Scheibe	Arandela	
A Group	... 1 02 24-7178	Screw	Vis	Schraube	Tornillo	2
A Group	... 4 01 24-8784	Lockwasher	Rondelle frein	Sicherungsscheibe	Freno	
A Group	... 1 05 27-4401	Nut	Écrou	Mutter	Tuerca	
A Group	... 4 05 28-0243	Plug	Bouchon	Stopfen	Tapon	
A Group	... 4 03 28-2080	Grease Nipple	Graisseur	Schmiernippel	Engrasador	
A Group	... 1 07 29-3250	Rubber Pad	Tampon caoutchouc	Gummiauflage	Cojin de goma	
A Group	... 1 37 42-3017	Lever	Levier	Hebel	Palanca	
A Group	... 1 06 42-3159	Rubber Pad	Tampon caoutchouc	Gummiauflage	Cojin de goma	
A Group	... 1 43 42-3160	Kickstart Spindle complete	Arbre du kick complet	Kickstarterwelle kompl.	Arbol del arrancador completa	
A7, A7S/S, A10	... 1 40 42-3167	Starter Pedal	Pedale de kick	Starthebel	Arrancador	
A Group	... 1 61 42-3247	Inner Cover	Couvercle intérieur	Innere Schutzkappe	Tapa interior	
A Group	... 1 03 64-3106	Gasket	Joint	Dichtung	Empaquetadura	
A Group	... 4 05 65-2157	Screw	Vis	Schraube	Tornillo	
A Group	... 1 07 65-3061	Screw	Vis	Schraube	Tornillo	2
A Group	... 1 05 65-3361	Screw	Vis	Schraube	Tornillo	
Spitfire Scrambler	... 1 37 65-3417	Lever	Levier	Hebel	Palanca	
A Group	... 4 04 66-3074	Dowel	Goujon	Passtift	Pasador	2
A Group	... 1 05 67-1705	Screw (short)	Vis (courte)	Schraube (kurz)	Tornillo (corte)	
A Group	... 1 01 67-1709	Washer	Rondelle	Scheibe	Arandela	
A Group	... 1 18 67-3024	Cover	Couvercle	Schutzkappe	Tap	
A Group	... 1 05 67-3034	Nut	Écrou	Mutter	Tuerca	4
A Group	... 1 16 67-3151	Bush	Douille	Büchse	Casquillo	
A Group	... 1 07 67-3152	Kickstart Stop	Butée de kick	Kickstarter-Anschlag	Dispositivo de tope	
A Group	... 1 14 67-3153	Bush	Douille	Büchse	Casquillo	
A Group	... 1 11 67-3174	Spring	Ressort	Feder	Resorte	
A Group	... 1 07 67-3176	Screw	Vis	Schraube	Tornillo	
A Group	... 1 09 67-3350	Pivot Pin	Axe	Drehzapfen	Eje	
A Group	... 1 54 67-3351	Outer Cover	Couvercle extérieur	Aussen Schutzkappe	Tapa exterior	
A Group	... 1 02 67-3354	Gasket	Joint	Dichtung	Empaquetadura	

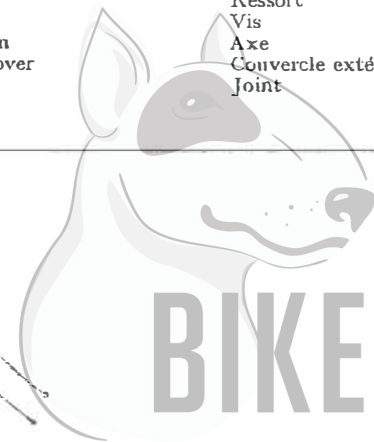

**CLASSIC
BIKE SPARES**

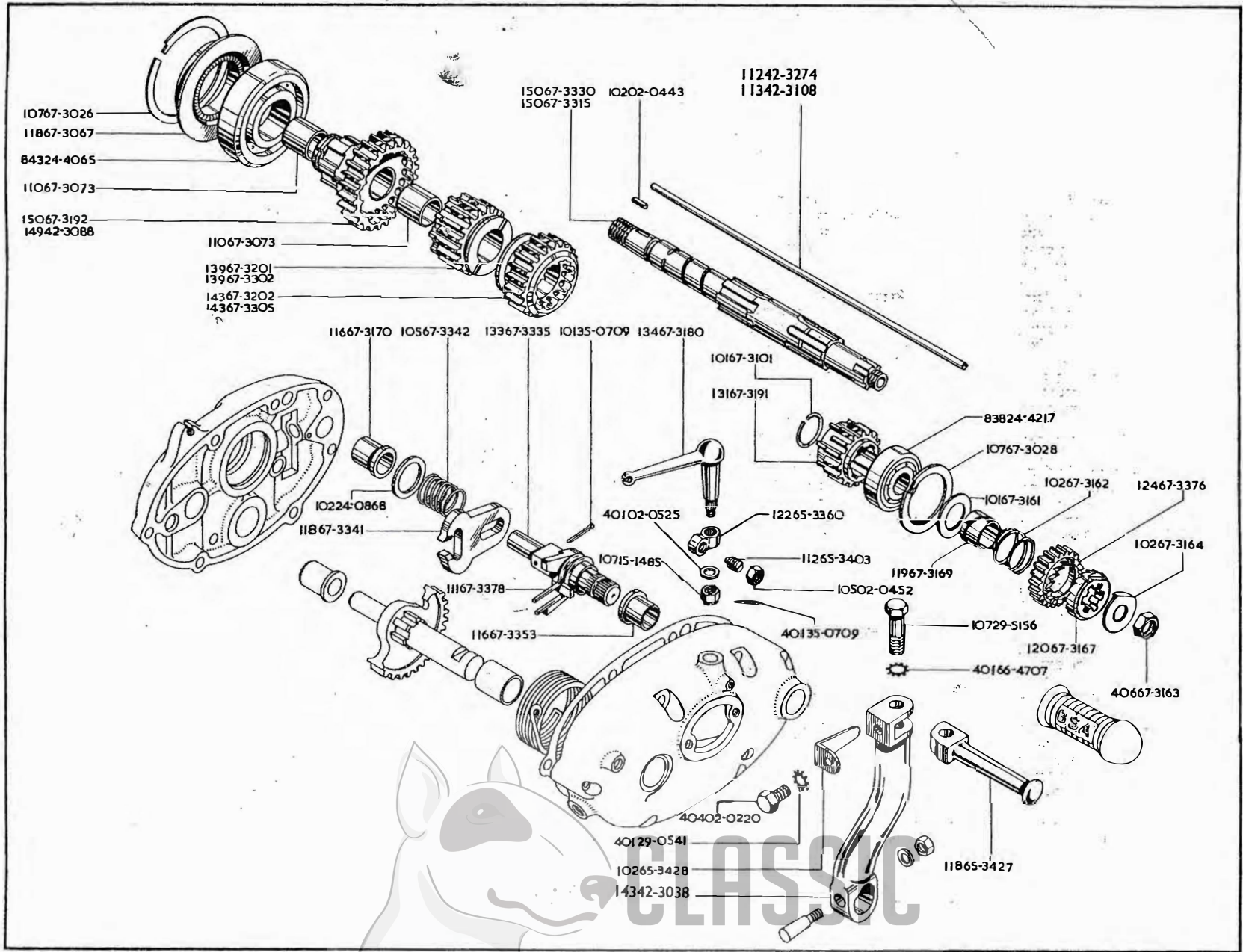

CLASSIC
 BIKE SPARES

**GEAR CLUSTER
JEU D'ENGRENAGES
ZAHNRADSTAZ
JUEGO DE ENGRANAJES**

Model Modèle Typen Modelos	Spares No. No. de pièce Ersatzteil-Nr. No. de repuesto	Description	Designation	Beschreibung	Descripción	Per Set Par jeu Pr. Satz Juego de
A Group	... 4 04 02-0220	Bolt	Boulon	Schraube	Tornillo	
A Group	... 1 02 02-0443	Key	Clavette	Rundkeil	Chaveta	
A Group	... 1 05 02-0452	Nut	Écrou	Mutter	Tuerca	
A Group	... 4 01 02-0525	Washer	Rondelle	Scheibe	Arandela	
A Group	... 1 07 15-1485	Nut	Écrou	Mutter	Tuerca	
A Group	... 1 02 24-0868	Washer	Rondelle	Scheibe	Arandela	
A Group	... 8 43 24-4065	Bearing	Roulement	Lager	Rolamiento	
A Group	... 8 38 24-4217	Bearing	Roulement	Lager	Rolamiento	
A Group	... 4 01 29-0541	Lockwasher	Rondelle frein	Sicherungsscheibe	Freno	
A Group	... 1 07 29-5156	Bolt	Boulon	Schraube	Tornillo	
A Group	... 4 01 35-0702	Split Pin	Goupille fendue	Splint	Chaveta hendida	
A Group	... 1 01 35-0709	Split Pin	Goupille fendue	Splint	Chaveta hendida	
A Group	... 1 45 42-3027	Lever complete	Levier complet	Hebel komplett	Palanca completa	
A Group	... 1 45 42-3028	Lever	Levier	Hebel	Palanca	
Spitfire Scrambler	... 1 45 42-3037	Kickstart Lever complete	Levier complet	Hebel komplett	Palanca completa	
Spitfire Scrambler	... 1 43 42-3038	Lever	Levier	Hebel	Palanca	
Spitfire Scrambler	... 1 49 42-3088	Pinion (25T)	Pignon D-25	Ritzel Z-25	Piñón D-25	
A Group	... 1 13 42-3108	Clutch Rod	Tige de traction	Kupplungstange	Varrilla del embrague	
A10S/R	... 1 12 42-3274†	Clutch Rod	Tige de traction	Kupplungstange	Varrilla del embrague	
A Group	... 1 22 65-3360	Lever	Levier	Hebel	Palanca	
A Group	... 1 12 65-3403	Screw	Vis	Schraube	Tornillo	
A Group	... 1 18 65-3427	Pedal	Pédale	Hebel	Palanca	
A Group	... 1 02 65-3428	Spring	Ressort	Feder	Resorte	
A Group	... 4 01 66-4707	Lockwasher	Rondelle frein	Sicherungsscheibe	Freno	
A Group	... 1 07 67-3026	Circlip	Arrêtoir	Sprengring	Freno	
A Group	... 1 07 67-3028	Circlip	Arrêtoir	Sprengring	Freno	
A Group	... 1 18 67-3067	Oil Seal	Joint d'huile	Simmerring	Reten de aceite	
A Group	... 1 10 67-3073	Bush	Douille	Büchse	Casquillo	2
A Group	... 1 01 67-3101	Circlip	Arrêtoir	Sprengring	Freno	
A Group	... 1 01 67-3161	Washer	Rondelle	Scheibe	Arandela	
A Group	... 1 02 67-3162	Spring	Ressort	Feder	Resorte	

†Fitted on and after Engine
No. DA10R-2443.

†Montée depuis moteur numéro
DA10R-2443.

†Nach Motornummer DA10R-
2443 montiert.

†Montada después de motor
numero DA10R-2443.

CLASSIC
BIKE SPARES

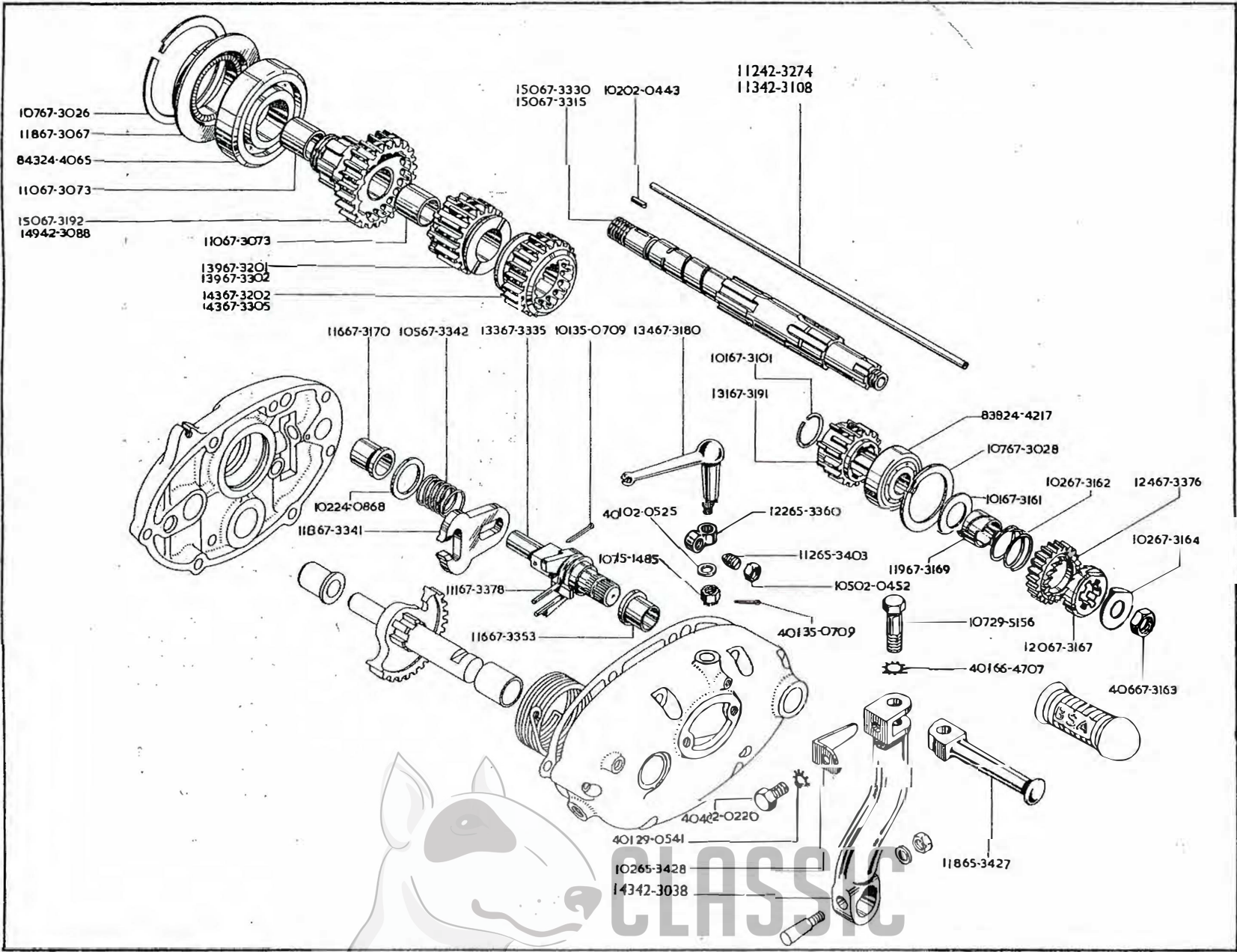

CLASSIC
 BIKE SPARES

**GEAR CLUSTER
JEU D'ENGRENAGES
ZAHNRADSTAZ
JUEGO DE ENGRANAJES**

Model Modèle Typen Modelos	Spare No. No. de pièce Ersatzteil-Nr. No. de repuesto	Description	Designation	Beschreibung	Descripción	Per Set Par jeu Pr. Satz Juego de
A Group	... 4 06 67-3163	Nut	Écrou	Mutter	Tuerca	
A Group	... 1 02 67-3164	Lockwasher	Rondelle frein	Sicherungsscheibe	Freno	
A Group	... 1 20 67-3167	Kickstart Sprocket	Pignon du kick	Kickstarterritzel	Piñón del arrancador	
A Group	... 1 19 67-3169	Bush	Douille	Büchse	Casquillo	
A Group	... 1 16 67-3170	Bush	Douille	Büchse	Casquillo	
A Group	... 1 34 67-3180	Lever	Levier	Hebel	Palanca	
A Group	... 1 31 67-3191	Pinion (16T)	Pignon D-16	Ritzel Z-16	Piñón D-16	
A Group	... 1 50 67-3192	Pinion (26T)	Pignon D-26	Ritzel Z 26	Piñón D-26	
A Group	... 1 39 67-3201	Pinion (20T)	Pignon D-20	Ritzel Z-20	Piñón D-20	
A Group	... 1 43 67-3202	Pinion (24T)	Pignon D-24	Ritzel Z-24	Piñón D-24	
Spitfire Scrambler	... 1 39 67-3302	Pinion (19T)	Pignon D-19	Ritzel Z-19	Piñón D-19	
Spitfire Scrambler	... 1 43 67-3305	Pinion (22T)	Pignon D-22	Ritzel Z-22	Piñón D-22	
Spitfire Scrambler	... 1 54 67-3314	Mainshaft complete	Arbre primaire complet	Getriebewelle	Arbol principal completa	
Spitfire Scrambler	... 1 50 67-3315	Mainshaft	Arbre primaire	Getriebewelle kompl.	Arbol principal	
A Group	... 1 54 67-3329	Mainshaft complete	Arbre primaire complet	Getriebewelle kompl.	Arbol principal completa	
A Group	... 1 50 67-3330	Mainshaft	Arbre primaire	Getriebewelle	Arbol principal	
A Group	... 1 33 67-3335	Spindle	Arbre	Welle	Arbol	
A Group	... 1 18 67-3341	Selector Fork	Fourchette de commande de changement de vitesses.	Schaltgabel	Horquilla de mando de caja de velocidades.	
A Group	... 1 05 67-3342	Spring	Ressort	Feder	Resorte	
A Group	... 1 16 67-3353	Bush	Douille	Büchse	Casquillo	
A Group	... 1 24 67-3376	Pinion (17T)	Pignon D-17	Ritzel Z-17	Piñón D-17	
A Group	... 1 11 67-3378	Spring	Ressort	Feder	Resorte	



**CLASSIC
BIKE SPARES**

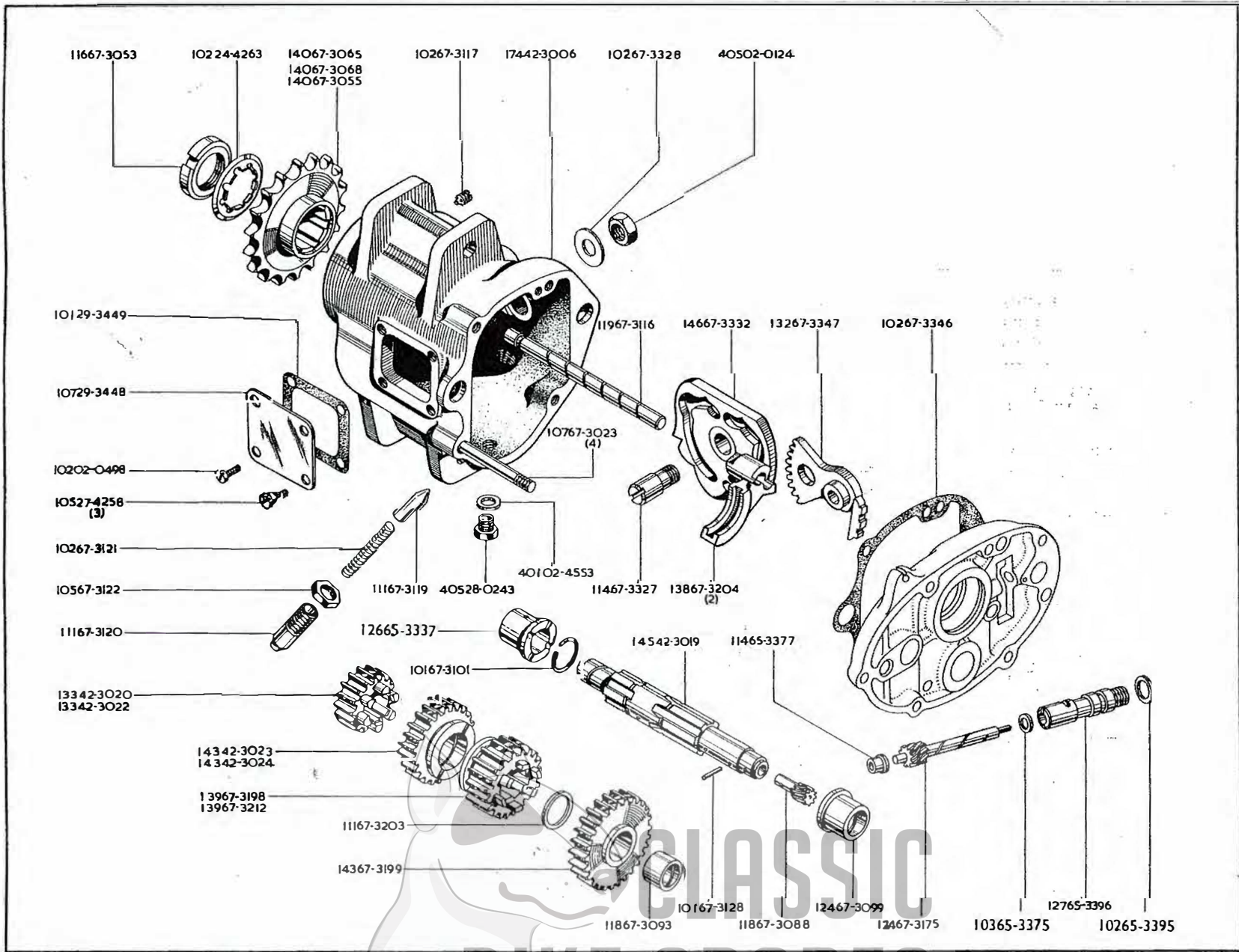

CLASSIC
 BIKE SPARES

**GEARBOX
BOÎTE DE VITESSES
GETRIEBEGEHÄUSE
CAJA DE VELOCIDADES**

Model Modèle Typen Modelos	Spares No. No. de pièce Ersatzteil-Nr. No. de repuesto	Description	Designation	Beschreibung	Descripción	Per Set Par jeu Pr. Satz Juego de
A Group	4 05 02-0124	Nut	Écrou	Mutter	Tuerca	
A Group	1 02 02-0498	Screw	Vis	Schraube	Tornillo	
A Group	4 01 02-4553	Sealing Washer	Joint d'étanchéité	Dichtung	Arandela de reten	
A Group	1 02 24-4263	Lockwasher	Rondelle frein	Sicherungsscheibe	Freno	
A Group	1 05 27-4258	Screw	Vis	Schraube	Tornillo	3
A Group	4 05 28-0243	Drain Plug	Bouchon de vidange d'huile	Ablassschraube	Tapón	
A Group	1 07 29-3448	Cover	Convercle	Schutzkappe	Tapa	
A Group	1 01 29-3449	Gasket	Joint	Dichtung	Empaquetadura	
A Group	1 74 42-3006	Gearbox Case	Carter de boîte de vitesses	Getriebegehäuse	Caja de velocidades	
A Group	1 50 42-3018	Layshaft complete	Arbre secondaire complet	Vorgelegewelle kompl.	Arbol de reenvio completa	
A Group	1 45 42-3019	Layshaft	Arbre secondaire	Vorgelegewelle	Arbol de reenvio	
A Group	1 33 42-3020	Pinion (17T)	Pinion D-17	Ritzel Z-17	Piñón D-17	
Spitfire Scrambler	1 50 42-3021	Layshaft complete	Arbre secondaire complet	Vorgelegewelle kompl.	Arbol de reenvio completa	
Spitfire Scrambler	1 33 42-3022	Pinion (18T)	Pinion D-18	Ritzel Z-18	Piñón D-18	
A Group	1 43 42-3023	Pinion (23T)	Pinion D-23	Ritzel Z-23	Piñón D-23	
Spitfire Scrambler	1 43 42-3024	Pinion (24T)	Pinion D-24	Ritzel Z-24	Piñón D-24	
A Group	1 26 65-3337	Bush	Douille	Büchse	Casquillo	
A Group	1 03 65-3375	Washer	Rondelle	Scheibe	Arandela	
A Group	1 14 65-3377	Bush	Douille	Büchse	Casquillo	
A Group	1 02 65-3395	Sealing Washer	Joint d'étanchéité	Dichtung	Arandela de reten	
A Group	1 27 65-3396	Bush	Douille	Büchse	Casquillo	
A Group	1 07 67-3023	Stud	Goujon	Stehbolzen	Esparago	4
A Group	1 16 67-3053	Nut	Écrou	Mutter	Tuerca	
Spitfire Scrambler	1 40 67-3055	Sprocket (16T)	Pignon à chaîne D-16	Ritzel Z-16	Piñón D-16	
A7, A10 Solo, A10 S/car	1 40 67-3065	Sprocket (19T)	Pignon à chaîne D-19	Ritzel Z-19	Piñón D-19	
A7 Sidecar	1 40 67-3068	Sprocket (17T)	Pignon à chaîne D-17	Ritzel Z-17	Piñón D-17	
A Group	1 18 67-3088	Pinion (6T)	Pinion D-6	Ritzel Z-6	Piñón D-6	
A Group	1 18 67-3093	Bush	Douille	Büchse	Casquillo	
A Group	1 43 42-3097	Pinion (27T)	Pinion D-27	Ritzel Z-27	Piñón D-27	
A Group	1 24 67-3099	Bush	Douille	Büchse	Casquillo	
A Group	1 01 67-3101	Circlip	Arrêtoir	Sprengring	Freno	
A Group	1 19 67-3116	Spindle	Arbre	Welle	Arbol	
A Group	1 02 67-3117	Screw	Vis	Schraube	Tornillo	
A Group	1 11 67-3119	Plunger	Plongeur	Plunger	Buzo	
A Group	1 11 67-3120	Plunger Housing	Logement du plongeur	Plungergehäuse	Caja de buzo	
A Group	1 02 67-3121	Spring	Ressort	Feder	Resorte	
A Group	1 05 67-3122	Nut	Écrou	Mutter	Tuerca	
A Group	1 01 67-3128	Peg	Érgot	Stift	Esparago	
A Group	1 24 67-3175	Drive Shaft	Arbre d'entraînement	Antriebswelle	Arbol de transmision	
A Group	1 39 67-3198	Pinion (19T)	Pinion D-19	Ritzel Z-19	Piñón D-19	
A Group	1 11 67-3203	Washer	Rondelle	Scheibe	Arandela	
A Group	1 38 67-3204	Selector Fork	Fourchette de sélecteur	Schaltgabel	Horquilla de mando de caja de velocidades.	2
Spitfire Scrambler	1 39 67-3212	Pinion (21T)	Pinion D-21	Ritzel Z-21	Piñón D-21	
A Group	1 14 67-3327	Pivot Pin	Axe	Drehzapfen	Eje	
A Group	1 02 67-3328	Washer	Rondelle	Scheibe	Arandela	
A Group	1 46 67-3332	Cam Plate	Plaque de came	Nockenplatte	Placa de leva	
A Group	1 02 67-3346	Gasket	Joint	Dichtung	Empaquetadura	
A Group	1 32 67-3347	Quadrant	Secteur	Quadrant	Sector	

Solo
S/car.

Solo
Sidecar

Solo
Beiwagen

Solo
Sidecar

CLASSIC
BIKE SPARES

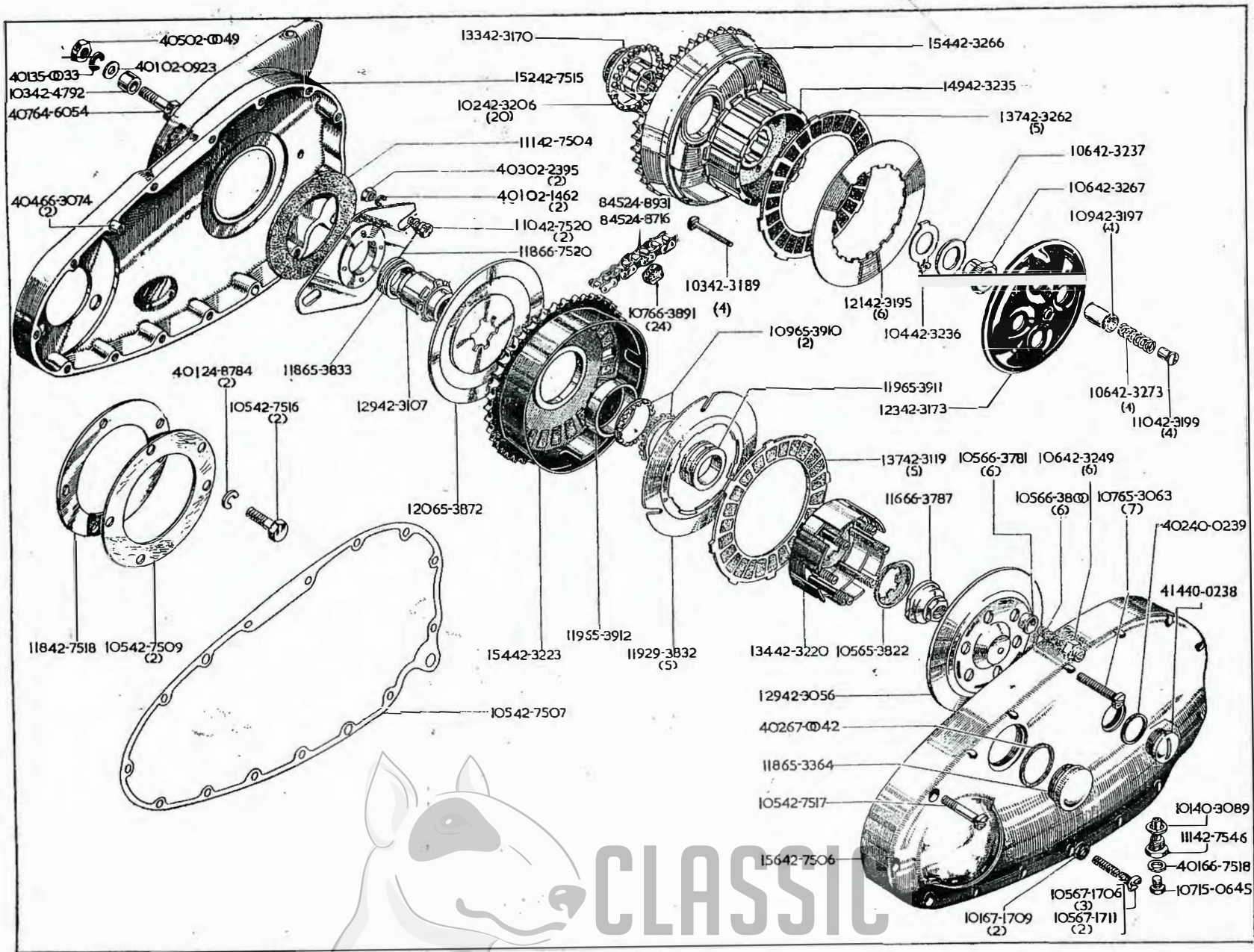

CLASSIC
BIKE SPARES

**CLUTCH
EMBAYAGE
KUPPLUNG
EMBRAGUE**

**PRIMARY COVER
COUVERCLE PRIMAIRE
PRIMARKAPPE
TAPA PRIMARIO**

Model Modèle Typen Modelos	Spares No. No. de pièce Ersatzteil-Nr. No. de repuesto	Description	Designation	Beschreibung	Descripción	Per Set Par jeu Pr. Satz Juego de
A Group ...	4 05 02-0049	Nut	Écrou	Mutter	Tuerca	
A Group ...	4 01 02-0923	Washer	Rondelle	Scheibe	Arandela	
A Group ...	4 01 02-1462	Spring Washer	Arrêtoir	Sicherung	Freno	2
A Group ...	4 03 02-2395	Nut	Écrou	Mutter	Tuerca	2
A Group ...	1 07 15-0645	Bolt	Boulon	Schraube	Tornillo	
A7, A7S/S Solo, S/car	8 45 24-8716	Chain	Chaîne	Kette	Cadena	
A10, A10S/R S/car ...	8 45 24-8716	Chain	Chaîne	Kette	Cadena	
A Group ...	4 01 24-8784	Spring Washer	Arrêtoir	Sicherung	Freno	2
A10, A10S/R (Solo) ...	8 45 24-8931	Chain (Solo)	Chaîne	Kette	Cadena	
A Group ...	1 19 29-3832	Driven Plate	Disque entraîné	Reibscheibe	Disco accionado	5
A Group ...	4 01 35-0033	Lockwasher	Rondelle frein	Sicherungsscheibe	Freno	
A Group ...	4 14 40-0238	Cap	Chapeau	Abdeckkappe	Tapon	
A Group ...	4 02 40-0239	Sealing Washer	Joint	Dichtung	Arandela de reten	
A Group ...	1 01 40-3089	Sealing Washer	Joint	Dichtung	Arandela de reten	
A Group ...	1 29 42-3056	Pressure Plate	Plaque de pression	Druckscheibe	Placa de presión	
A Group ...	1 29 42-3107	Clutch Sleeve	Manchon de l'embrayage	Kupplungsmitnehmer	Mangueto de embrague	
A Group ...	1 37 42-3119	Driving Plate complete	Disque d'entraînement complet	Mitnehmerplatte kompl.	Placa de manda	5
A Group ...	1 33 42-3170†	Clutch Sleeve	Manchon de l'embrayage	Kupplungsmitnehmer	Mangueto de embrague	
A Group ...	1 23 42-3173†	Pressure Plate	Plaque de pression	Druckscheibe	Placa de presión	
A Group ...	1 03 42-3189†	Bolt	Boulon	Schraube	Tornillo	4
A Group ...	1 21 42-3195†	Driven Plate	Disque entraîné	Reibscheibe	Disco accionado	6
A Group ...	1 09 42-3197†	Spring Cup	Siege de ressort	Federhülse	Copa	4
A Group ...	1 10 42-3199†	Nut	Écrou	Mutter	Tuerca	4
A Group ...	1 02 42-3206†	Roller	Rouleau	Rolle	Rodillo	20
A Group ...	1 34 42-3220	Clutch Centre	Moyeux d'embrayage	Kupplungsnahe	Cubo de embrague	
A Group ...	1 54 42-3223	Clutch Chainwheel	Couronne d'embrayage	Kupplungskettenrad	Piñón de cadena de embrague	
A Group ...	1 49 42-3235†	Clutch Centre	Moyeux d'embrayage	Kupplungsnahe	Cubo de embrague	
A Group ...	1 04 42-3236†	Lockwasher	Rondelle frein	Sicherungsscheibe	Freno	
A Group ...	1 06 42-3237†	Washer	Rondelle	Scheibe	Arandela	
A Group ...	1 06 42-3249	Nut	Écrou	Mutter	Tuerca	6

† Fitted on and after Engine No.
A7 ... CA7 8623
A7S/S ... CA7SS 8112
A10 ... DA10 13298
A10S/R ... DA10R 2443

† Montée depuis moteur numéro
A7 ... CA7 8623
A7S/S ... CA7SS 8122
A10 ... DA10 13298
A10S/R ... DA10R 2443

† Nach Motornummer montiert
A7 ... CA7 8623
A7S/S ... CA7SS 8112
A10 ... DA10 13298
A10S/R ... DA10R 2443

† Montada después de motor numero
A7 ... CA7 8623
A7S/S ... CA7SS 8112
A10 ... DA10 13298
A10S/R ... DA10R 2443

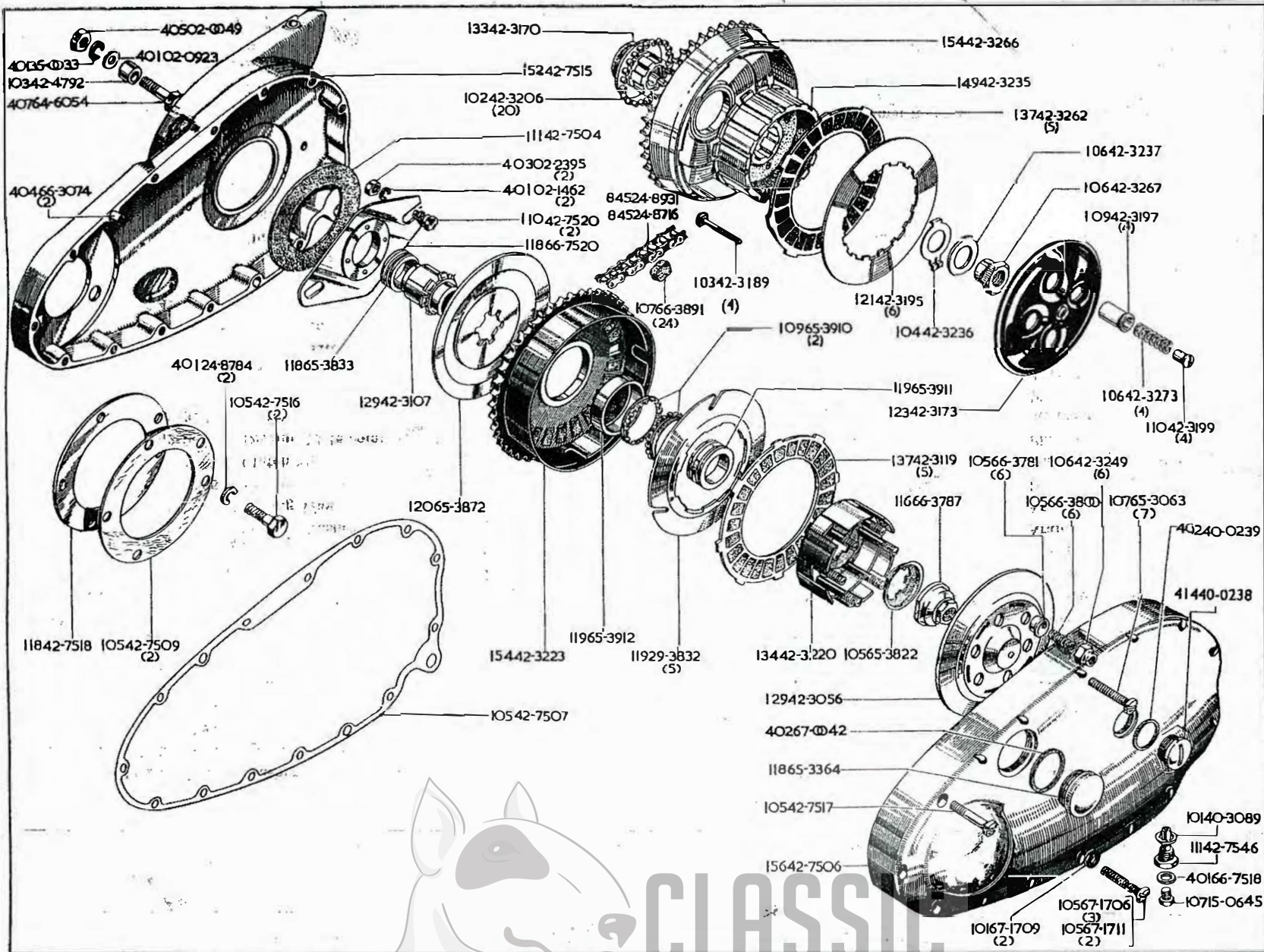

CLASSIC
 BIKE SPARES

**CLUTCH
EMBRAYAGE
KUPPLUNG
EMBRAUGE**

**PRIMARY COVER
COUVERCLE PRIMAIRE
PRIMARKAPPE
TAPA PRIMARIO**

Model Modèle Typen Modelos	Spares No. No. de pièce Ersatzteil-Nr. No. de repuesto	Description	Designation	Beschreibung	Descripción	Per Set Par jeu Pr. Satz Juego de
A Group	1 37 42-3262†	Driving Plate complete	Disque d'entraînement complet	Mitnehmerplatte kompl.	Placa de manda	5
A Group	1 54 42-3266†	Clutch Chainwheel	Couronne d'embrayage	Kupplungskettenrad	Piñón de cadena de embrague	
A Group	1 06 42-3267†	Nut	Écrou	Mutter	Tuerca	
A Group	1 06 42-3273†	Spring	Vis	Feder	Resorte	4
A Group	1 03 42-4792	Spacer Bush	Bague entretoise	Distanzbüchse	Anillito espaciador	
A Group	1 11 42-7504	Sealing Washer	Joint d'étanchéité	Dichtung	Arandela de reten	
A Group	1 56 42-7506	Primary Cover	Couvercle primaire	Primardeckel	Tapa primario	
A Group	1 05 42-7507	Gasket	Joint	Dichtung	Empaquetadura	
A Group	1 05 42-7509	Gasket	Joint	Dichtung	Empaquetadura	2
A Group	1 52 42-7515	Primary Cover	Couvercle primaire	Primardeckel	Tapa primario	
A Group	1 05 42-7516	Bolt	Boulon	Schraube	Tornillo	2
A Group	1 05 42-7517	Screw	Vis	Schraube	Tornillo	3
A Group	1 18 42-7518	Washer	Rondelle	Scheibe	Arandela	
A Group	1 10 42-7520	Bolt	Boulon	Schraube	Tornillo	2
A Group	1 11 42-7546	Drain Plug	Bouchon de vidange d'huile	Ablassschraube	Tapon	
A Group	4 07 64-6054	Bolt	Boulon	Schraube	Tornillo	7
A Group	1 07 65-3063	Screw	Vis	Schraube	Tornillo	
A Group	1 18 65-3364	Cap	Chapeau	Abdeckkappe	Tapon	
A Group	1 05 65-3822	Lockwasher	Rondelle frein	Sicherungsscheibe	Freno	
A Group	1 18 65-3833	Collar	Bague d'arrêt	Stellring	Anillo móvil aprisionado	
A Group	1 20 65-3872	Clutch Plate	Disque extérieur d'embrayage	Ausser Kupplungscheibe	Disco exterior del embrague	
A Group	1 09 65-3910	Retainer	Arrêtoir	Sicherung	Freno	2
A Group	1 19 65-3911	Bush	Douille	Büchse	Casquillo	
A Group	1 19 65-3912	Ball Race Ring	Aneau de cage à billes	Kugellagerring	Anillo del collar de bolas	
A Group	4 04 66-3074	Dowel	Goupille cylindrique	Stift	Pasador	2
A Group	1 05 66-3781	Spring Cup	Siège de ressort	Federbüchse	Copa	6
A Group	1 16 66-3787	Nut	Écrou	Mutter	Tuerca	
A Group	1 05 66-3800	Spring	Ressort	Feder	Resorte	6
A Group	1 07 66-3891	Inserts	Garnitures	Einlagen	Guaniciones	24
A Group	4 01 66-7518	Sealing Washer	Joint	Dichtung	Arandela de reten	
A Group	1 18 66-7520	Sliding Plate	Plaque coulissante	Gleitscheibe	Placa deslizante	
A Group	4 02 67-0042	Sealing Washer	Joint	Dichtung	Arandela de reten	
A Group	1 05 67-1706	Screw	Vis	Schraube	Tornillo	3
A Group	1 01 67-1709	Sealing Washer	Joint	Dichtung	Arandela de reten	2
A Group	1 05 67-1711	Screw	Vis	Schraube	Tornillo	2

†Fitted on and after Engine No.

†Montée depuis moteur No.

†Nach Motornummer-montiert

†Montada después de motor numero

A7 ... CA7 8623
A7S/S ... CA7SS 8112
A10 ... DA10 13298
A10S/R... DA10R 2443

A7 ... CA7 8623
A7S/S ... CA7SS 8112
A10 ... DA10 13298
A10S/R... DA10R 2443

A7 ... CA7 8623
A7S/S ... CA7SS 8112
A10 ... DA10 13298
A10S/R... DA10R 2443

A7 ... CA7 8623
A7S/S ... CA7SS 8112
A10 ... DA10 13298
A10S/R... DA10R 2443

**CLASSIC
BIKE SPARES**

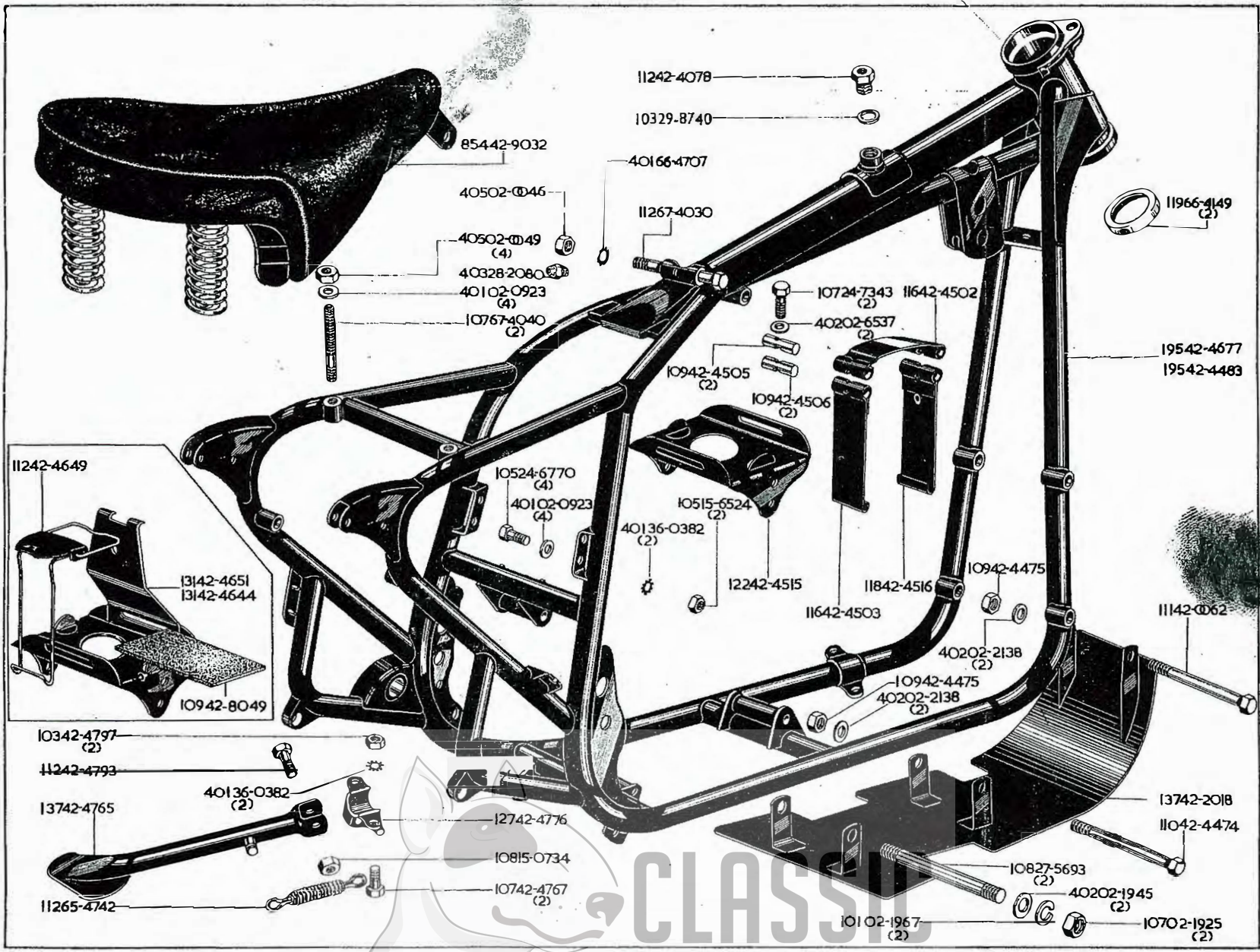

CLASSIC
 BIKE SPARES

**FRAME
CADRE
RAHMEN
CUADRO**

**PROP STAND
BEQUILLE LATÉRAL
SEITENSTÜTZE
MULETA LATERAL**

**BATTERY HOLDER
SUPPORT DE BATTERIE
BATTERIEHALTER
PORTA-BATERIA**

Model Modèle Typen Modelos	Spares No. No. de pièce Ersatzteil-Nr. No. de repuesto	Description	Designation	Beschreibung	Descripción	Per Set Par jeu Pr. Satz Juego de
A Group	4 05 02-0046	Nut	Écrou	Mutter	Tuerca	
A Group	4 05 02-0049	Nut	Écrou	Mutter	Tuerca	4
A Group	4 01 02-0923	Washer	Rondelle	Scheibe	Arandela	8
A Group	1 07 02-1925	Nut	Écrou	Mutter	Tuerca	2
A Group	4 02 02-1945	Washer	Rondelle	Scheibe	Arandela	2
A Group	1 01 02-1967	Lockwasher	Rondelle frein	Sicherungsscheibe	Freno	
Spitfire Scrambler	4 02 02-2138	Washer	Rondelle	Scheibe	Arandela	4
A Group	4 02 02-6537	Washer	Rondelle	Scheibe	Arandela	2
A Group	1 08 15-0734	Nut	Écrou	Mutter	Tuerca	
A Group	1 05 15-6524	Nut	Écrou	Mutter	Tuerca	2
A Group	1 05 24-6770	Bolt	Boulon	Schraube	Tornillo	4
A Group	1 07 24-7343	Bolt	Boulon	Schraube	Tornillo	2
Spitfire Scrambler	1 08 27-5693	Stud	Goujon	Stehbolzen	Esparago	
A Group	4 03 28-2080	Grease Nipple	Graisseur	Schmiernippel	Engrasador	1
A Group	4 03 29-8740	Washer	Rondelle	Scheibe	Arandela	2
A Group	4 01 36-0382	Lockwasher	Rondelle frein	Sicherungsscheibe	Freno	
Spitfire Scrambler	1 11 42-0062	Bolt	Boulon	Schraube	Tornillo	
Spitfire Scrambler	1 37 42-2018	Crankcase Shield	Plaque couvercle	Abdeckplatte	Tapa del cojinete	
A Group	1 12 42-4078	Socket	Douille	Socket	Casquillo	
Spitfire Scrambler	1 10 42-4474	Bolt	Boulon	Schraube	Tornillo	
Spitfire Scrambler	1 09 42-4475	Nut	Écrou	Mutter	Tuerca	2
A Group	1 16 42-4502	Battery Strap	Barrette de batterie	Batteriehalter	Soporte de bateria	
A Group	1 16 42-4503	Battery Strap	Barrette de batterie	Batteriehalter	Soporte de bateria	
A7S/S, A10S/R	1 16 42-4503	Battery Strap	Barrette de batterie	Batteriehalter	Soporte de bateria	2
A Group	1 09 42-4505	Pivot Pin	Axe	Drehzapfen	Eje	2
A Group	1 09 42-4506	Pivot Pin (tapped)	Chèville de rotation-filetée	Drehstift mit Gewinde	Espiga de rotación-roscado	
A Group	1 34 42-4514	Battery Holder complete	Support de batterie complet	Batteriehalter kompl.	Porta-bateria completa	
A Group	1 22 42-4515	Base Plate	Embase	Unterlage	Placa de base	
A7, A10	1 18 42-4516	Battery Strap (side)	Barrette de batterie (côte)	Batteriehalter (seite)	Soporte de bateria (lado)	
A7, A10	1 31 42-4644*	Base Plate	Embase	Unterlage	Placa de base	
A Group	1 12 42-4649*	Wire Clip	Agrafe	Spannbügel	Estribo	
A7S/S, A10S/R	1 31 42-4651*	Base Plate	Embase	Unterlage	Placa de base	
A Group	1 37 42-4765	Prop Stand	Béquille latérale	Seitenstütze	Muleta lateral	
A Group	1 07 42-4767	Bolt	Boulon	Schraube	Tornillo	2
A Group	1 27 42-4776	Bracket	Support	Verstrebung	Soporte	
A Group	1 12 42-4793	Bolt	Boulon	Schraube	Tornillo	
A Group	1 03 42-4797	Nut	Écrou	Mutter	Tuerca	2
A Group	1 09 42-8049*	Rubber Mat	Recouvrement caoutchouc	Gummibelag	Estera de goma	
A Group	8 54 42-9032	Saddle	Selle	Sattel	Sillín	
A Group	1 12 65-4742	Spring	Ressort	Feder	Resorte	
A Group	1 19 66-4149	Bearing Cup	Cuvette de roulement	Lagerschale	Copa de rolaniento	2
A Group	4 01 66-4707	Lockwasher	Rondelle frein	Sicherungsscheibe	Freno	
A Group	1 12 67-4030	Bolt	Boulon	Schraube	Tornillo	
A Group	1 07 67-4040	Stud	Goujon	Stehbolzen	Esparago	2

*Fitted on and after Frame

No. A7 GA7-8855
A7S/S GA7-8929
A10 GA7-8437
A10S/R GA7-8618

*Montée depuis cadre numéro

A7 GA7-8855
A7S/S GA7-8929
A10 GA7-8437
A10S/R GA7-8618

*Nach Rahmennummer montiert

A7 GA7-8855
A7S/S GA7-8929
A10 GA7-8437
A10S/R GA7-8618

*Montada después de cuadro

numero A7 GA7-8855
A7S/S GA7-8929
A10 GA7-8437
A10S/R GA7-8618

CLASSIC
BIKE SPARES

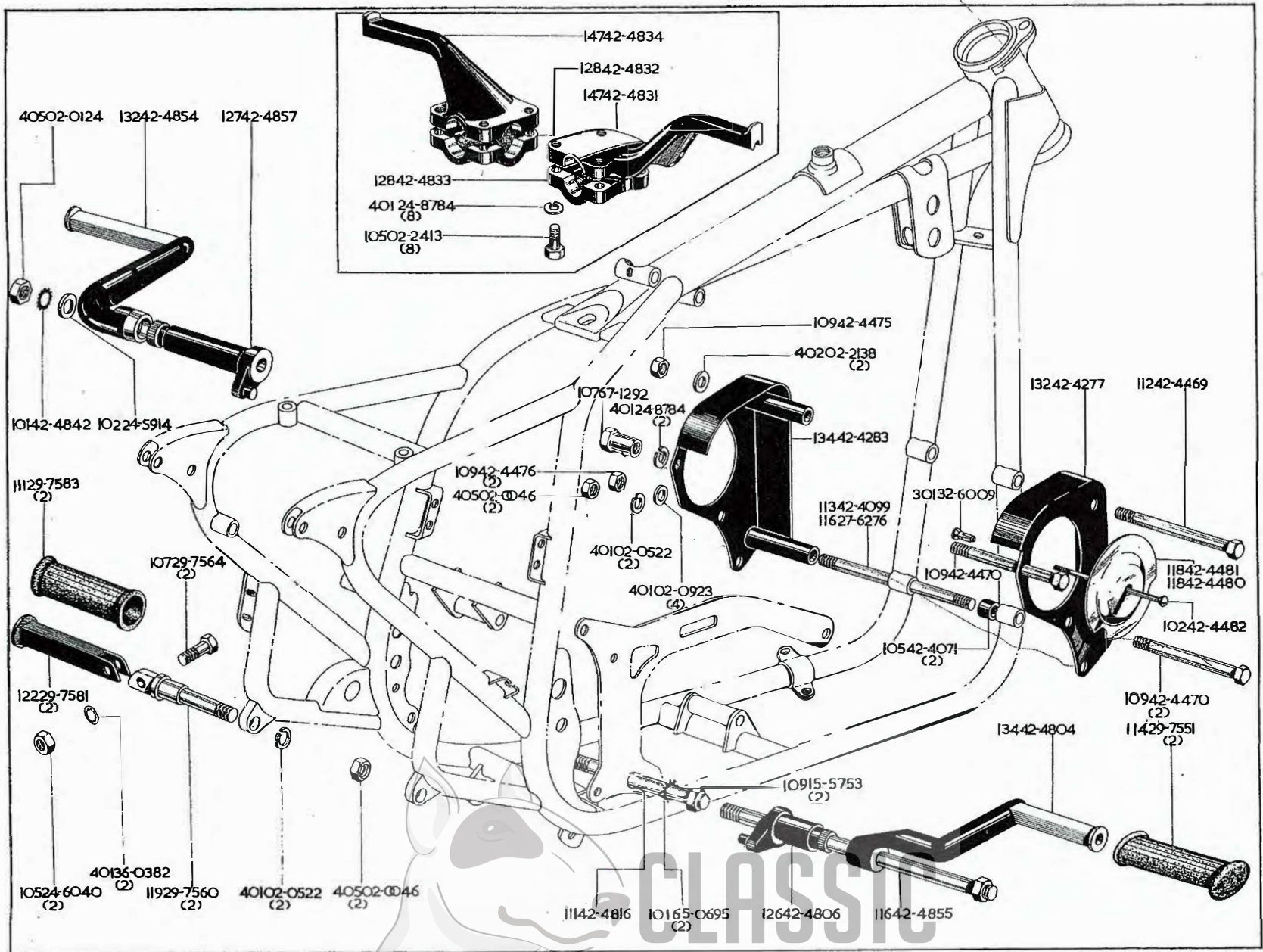

CLASSIC
 BIKE SPARES

**ENGINE PLATES
PLAQUE D'APPUI POUR MOTEUR
MOTORABSTÜTZBLECH
PLACA DE APOYO DEL MOTOR**

**FOOTRESTS
REPOSE-PIED
FUSSRASTEN
DESCANSA-PIES**

Model Modèle Typen Modelos	Spares No. No. de pièce Ersatzteil-Nr. No. de repuesto	Description	Designation	Beschreibung	Descripción	Per Set Par jeu Pr. Satz Juego de
A Group	4 05 02-0046	Nut	Écrou	Mutter	Tuerca	4
A Group	4 05 02-0124	Nut	Écrou	Mutter	Tuerca	
A Group	4 01 02-0522	Lockwasher	Rondelle frein	Sicherungsscheibe	Freno	4
A Group	4 01 02-0923	Washer	Rondelle	Scheibe	Arandela	4
A Group	4 02 02-2138	Washer	Rondelle	Scheibe	Arandela	2
Spitfire Scrambler	1 05 02-2413	Nut	Écrou	Mutter	Tuerca	8
Spitfire Scrambler	1 09 15-5753	Nut	Écrou	Mutter	Tuerca	2
A Group	1 02 24-5914	Washer	Rondelle	Scheibe	Arandela	
A Group	1 05 24-6040	Nut	Écrou	Mutter	Tuerca	2
A Group	4 01 24-8784	Lockwasher	Rondelle frein	Sicherungsscheibe	Freno	8
A Group	1 16 27-6276	Stud	Goujon	Stehbolzen	Esparago	
A Group	1 14 29-7551	Rubber Pad	Caoutchouc tampon	Gummiauflege	Cojin de goma	2
A Group	1 19 29-7560	Anchor Bolt	Boulon d'ancrage	Ankerbolzen	Tornillo de sujeción	2
A Group	1 07 29-7564	Bolt	Boulon	Schraube	Tornillo	2
A Group	1 22 29-7581	Footrest	Repose-pied	Fussraste	Descansa-pie	2
A Group	1 11 29-7583	Rubber Pad	Caoutchouc tampon	Gummiauflege	Cojin de goma	2
Spitfire Scrambler	3 01 32-6009	Nipple	Ecrou de rayon	Nippel	Tuerca	
A Group	4 01 36-0382	Lockwasher	Rondelle frein	Sicherungsscheibe	Freno	2
A Group	1 05 42-4071	Distance Piece	Entretoise	Distanzrohr	Distanciador	
A Group	1 13 42-4099	Stud	Goujon	Stehbolzen	Esparago	
A Group	1 32 42-4277	Engine Plate (o/s)	Plaque d'appui pour moteur (droite).	Motorabstützblech (rechts)	Placa de apoyo del motor (der.)	
A Group	1 34 42-4283	Engine Plate (n/s)	Plaque d'appui pour moteur (gauche).	Motorabstützblech (links)	Placa de apoyo del motor (izq.)	
A Group	1 12 42-4469	Bolt	Boulon	Schraube	Tornillo	
A Group	1 09 42-4470	Bolt	Boulon	Schraube	Tornillo	3
A Group	1 09 42-4475	Nut	Écrou	Mutter	Tuerca	
A Group	1 09 42-4476	Nut	Écrou	Mutter	Tuerca	2
Spitfire Scrambler	1 18 42-4480	Plate (n/s)	Plaque (gauche)	Scheibe (links)	Placa (izq.)	
Spitfire Scrambler	1 18 42-4481	Plate (o/s)	Plaque (droite)	Scheibe (rechts)	Placa (der.)	
Spitfire Scrambler	1 02 42-4482	Dynamo Hole Cover Fastener.	Fermeur pour couvercle de trou de dynamo.	Verschluss für Dynamodeckelloch	Cerrojo para tapa de agujero de de dinamo.	
A Group	1 34 42-4804	Bracket (o/s)	Support (droite)	Verstrebung (rechts)	Soporte (der.)	
A Group	1 26 42-4806	Distance Piece (o/s)	Entretoise (droite)	Distanzrohr (rechts)	Distanciador (der.)	
Spitfire Scrambler	1 11 42-4816	Stud	Goujon	Stehbolzen	Esparago	
Spitfire Scrambler	1 47 42-4831	Footrest (o/s)	Repose-pied (droite)	Fussraste (rechts)	Descansa-pie (der.)	
Spitfire Scrambler	1 28 42-4832	Locking Plate (n/s)	Plaque de blocage (gauche)	Sicherungsscheibe (links)	Placa cerradora (izq.)	
Spitfire Scrambler	1 28 42-4833	Locking Plate (o/s)	Plaque de blocage (droite)	Sicherungsscheibe (rechts)	Placa cerradora (der.)	
Spitfire Scrambler	1 47 42-4834	Footrest (n/s)	Repose-pied (gauche)	Fussraste (links)	Descansa-pie (izq.)	
A Group	1 32 42-4835	Pillion Footrest assembled	Repose-pied arrière complet	Sozius Fussrasten kompl.	Estribo para acompañante	2
A Group	1 01 42-4842	Lockwasher	Rondelle frein	Sicherungsscheibe	Freno	
A Group	1 32 42-4854	Bracket (n/s)	Support (gauche)	Verstrebung (links)	Soporte (izq.)	
A Group	1 16 42-4855	Stud	Goujon	Stehbolzen	Esparago	
A Group	1 27 42-4857	Distance Piece (n/s)	Entretoise (gauche)	Distanzrohr (links)	Distanciador (izq.)	
Spitfire Scrambler	1 01 65-0695	Lockwasher	Rondelle frein	Sicherungsscheibe	Freno	
A Group	1 07 67-1292	Nut	Écrou	Mutter	Tuerca	

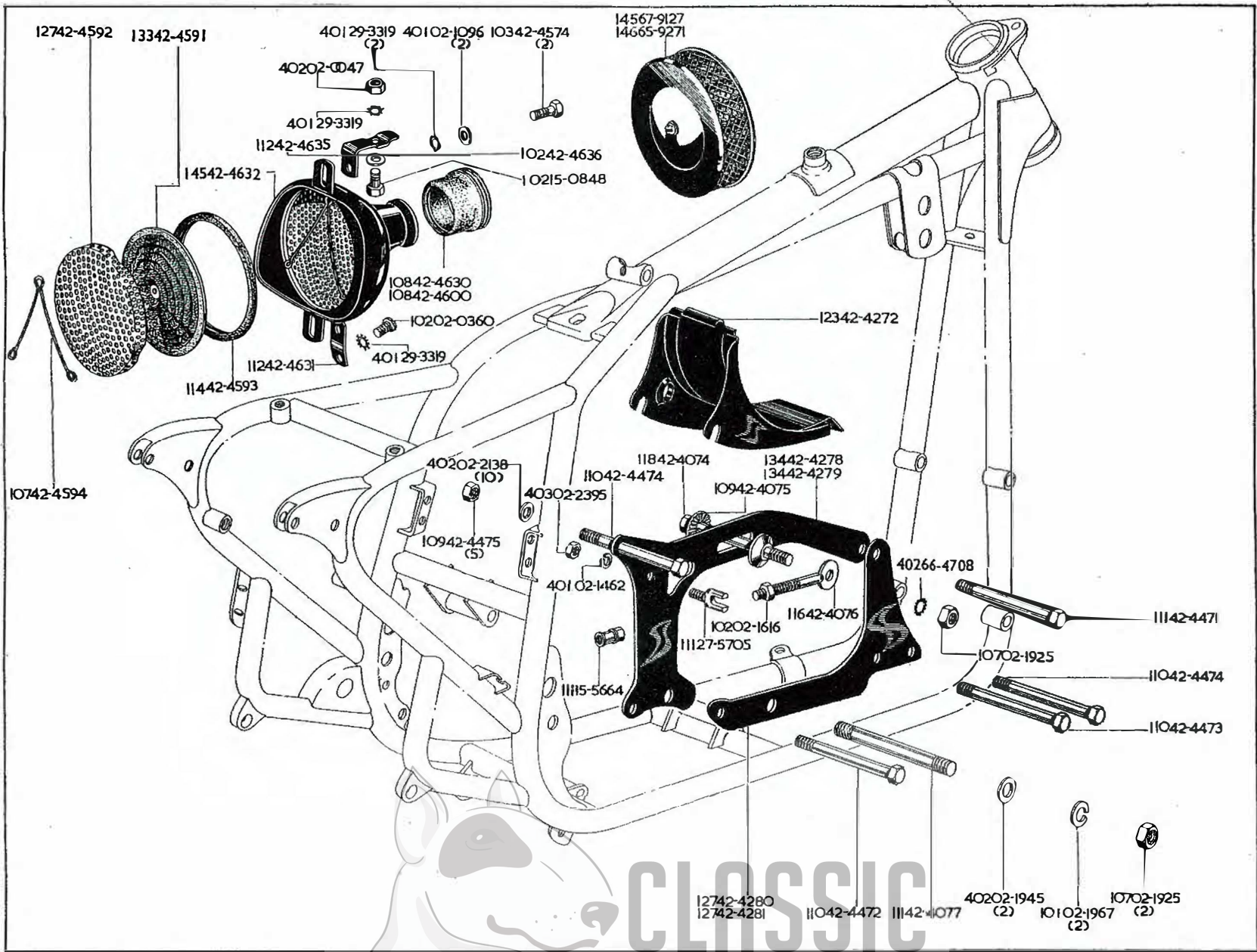

CLASSIC
 BIKE SPARES

**ENGINE PLATES
PLAQUE D'APPUE POUR MOTEUR
MOTOR ABSTUTZBLECH
PLACA DE APOYO DEL MOTOR**

**AIR FILTER
FILTRE À AIR
LUFTFILTER
FILTRO DE AIRE**

Model Modèle Typen Modelos	Spare No. No. de pièce Ersatzteil-Nr. No. de repuesto	Description	Designation	Beschreibung	Descripción	Per Set Par jeu Pr. Satz Juego de
Super Rocket, Spitfire Scrambler	4 02 02-0047*	Nut	Écrou	Mutter	Tuerca	
Super Rocket, Spitfire Scrambler	1 02 02-0360*	Bolt	Boulon	Schraube	Tornillo	
A7, A10 ...	4 01 02-1096	Washer	Rondelle	Scheibe	Arandela	2
A Group ...	4 01 02-1462	Lockwasher	Rondelle frein	Sicherungsscheibe	Freno	
A Group ...	1 02 02-1616	Nut	Écrou	Mutter	Tuerca	
A Group ...	1 07 02-1925	Nut	Écrou	Mutter	Tuerca	3
A Group ...	4 02 02-1945	Washer	Rondelle	Scheibe	Arandela	2
A Group ...	1 01 02-1967	Lockwasher	Rondelle frein	Sicherungsscheibe	Freno	2
A Group ...	4 02 02-2138	Washer	Rondelle	Scheibe	Arandela	10
A Group ...	4 03 02-2395	Nut	Écrou	Mutter	Tuerca	
Super Rocket, Spitfire Scrambler	1 02 15-0848*	Bolt	Boulon	Schraube	Tornillo	
A Group ...	1 11 15-5664	Nut	Écrou	Mutter	Tuerca	
A Group ...	1 11 27-5705	Stud	Goujon	Stehbolzen	Esparago	
A7, A10 ...	4 01 29-3319	Lockwasher	Rondelle frein	Sicherungsscheibe	Freno	2
A Group ...	1 18 42-4074	Stud	Goujon	Stehbolzen	Esparago	
A Group ...	1 09 42-4075	Lockwasher	Rondelle frein	Sicherungsscheibe	Freno	
A Group ...	1 16 42-4076	Adjuster	Système de réglage	Einstellschraube	Tornillo de ajuste	
A Group ...	1 11 42-4077	Stud	Goujon	Stehbolzen	Esparago	
A Group ...	1 23 42-4272	Cover Plate	Plaque couvercle (droite)	Abdeckplatte	Tapa del cojinete	
A Group ...	1 34 42-4278	Plate (top) (o/s)	Plaque (supérieur) (droite)	Scheibe (oben rechts)	Placa (superior) (der.)	
A Group ...	1 34 42-4279	Plate (top) (n/s)	Plaque (supérieur) (gauche)	Scheibe (oben links)	Placa (superior) (izq.)	
A Group ...	1 27 42-4280	Plate (bottom) (o/s)	Plaque (inférieur) (droite)	Scheibe (unten rechts)	Placa (inferior) (der.)	
A Group ...	1 27 42-4281	Plate (bottom) (n/s)	Plaque (inférieur) (gauche)	Scheibe (unten links)	Placa (inferior) (izq.)	
A Group ...	1 11 42-4471	Bolt	Boulon	Schraube	Tornillo	
A Group ...	1 10 42-4472	Bolt	Boulon	Schraube	Tornillo	
A Group ...	1 10 42-4473	Bolt	Boulon	Schraube	Tornillo	
A Group ...	1 10 42-4474	Bolt	Boulon	Schraube	Tornillo	2
A Group ...	1 09 42-4475	Nut	Écrou	Mutter	Tuerca	5
A7, A10 ...	1 03 42-4574	Screw	Vis	Schraube	Tornillo	2
A7, A10 ...	1 33 42-4591	Air Filter Element	Élément de filtre à air	Luftfiltereinsatz	Guarnición del filtro	
A7, A10 ...	1 27 42-4592	Air Filter Cover	Couvercle du filtre à air	Luftfilterdeckel	Tapa del filtro de aire	
A7, A10 ...	1 14 42-4593	Sealing Washer	Joint d'étanchéité	Dichtung	Arandela de reten	
A7, A10 ...	1 07 42-4594	Retainer	Arrêtoir	Sicherung	Freno	
A7, A10 ...	1 08 42-4600	Connector	Connexion	Verbinder	Conector	
A7, A10 ...	1 45 42-4625	Air Filter	Filtre à air	Luftfilter	Filtro de aire	
Super Rocket, Spitfire Scrambler	1 08 42-4630*	Rubber Sleeve	Douille caoutchouc	Gunmimuffe	Manguita de goma	
Super Rocket, Spitfire Scrambler	1 12 42-4631*	Bracket (bottom)	Support (inférieur)	Verstrebung (unten)	Soporte (inferior)	
Super Rocket, Spitfire Scrambler	1 45 42-4632	Air Filter	Filtre à air	Luftfilter	Filtro de aire	
Super Rocket, Spitfire Scrambler	1 39 42-4633*	Air Filter Body	Manchon pour filtre à air	Hülse für Luftfilter	Envoltura para filtro de aire	
Super Rocket, Spitfire Scrambler	1 12 42-4635*	Bracket (top)	Support (dessus)	Verstrebung (oben)	Soporte (superior)	
Super Rocket, Spitfire Scrambler	1 02 42-4636*	Washer	Rondelle	Scheibe	Arandela	
A7/S ...	1 46 65-9271	Air Filter	Filtre à air	Luftfilter	Filtro de aire	
A Group ...	4 02 66-4708	Lockwasher	Rondelle frein	Sicherungsscheibe	Freno	
A10S/R ...	1 45 67-9127	Air Filter	Filtre à air	Luftfilter	Filtro de aire	

*American type.

*Type American.

*Amerikanische Typen.

*Tipo Americano.

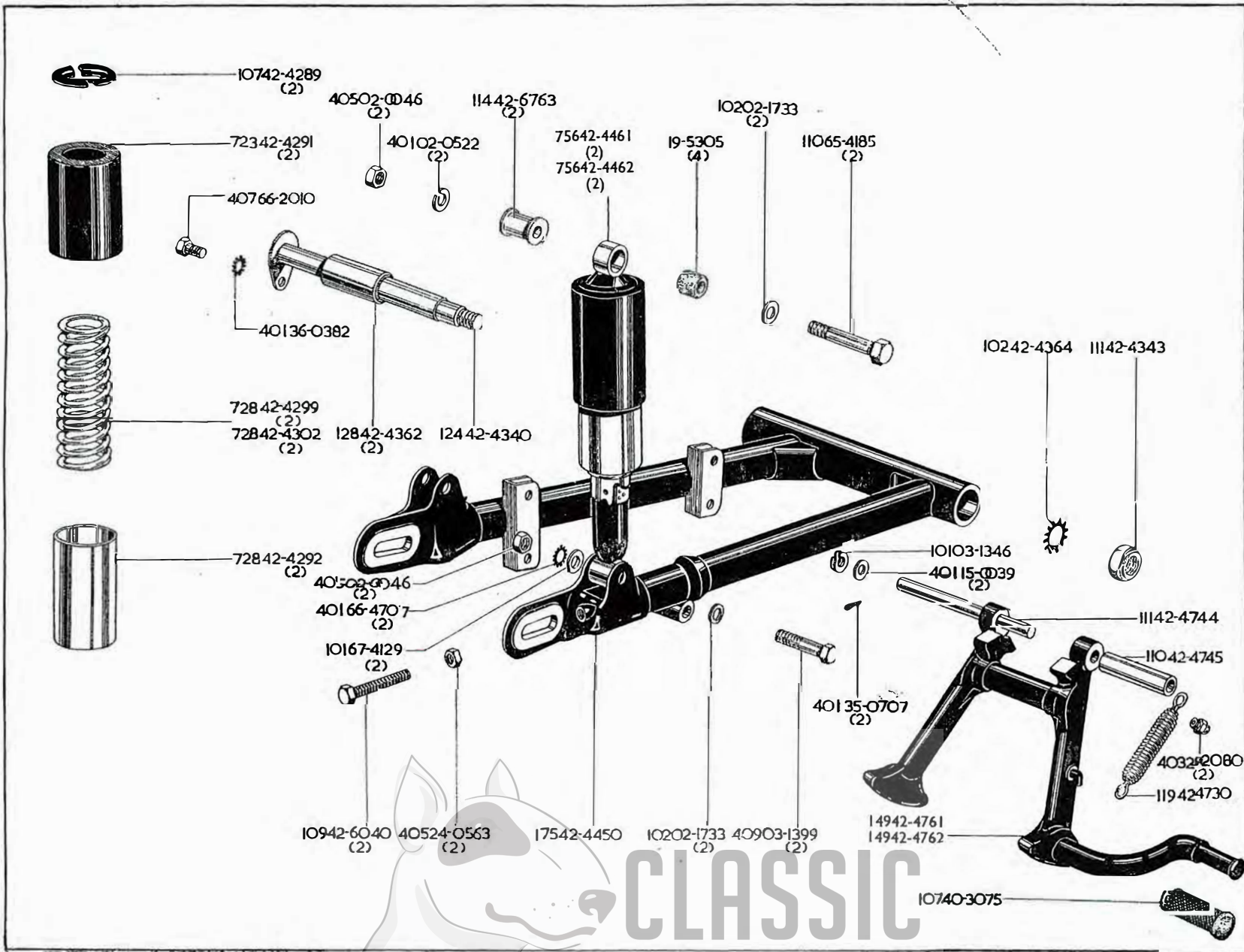

CLASSIC
 BIKE SPARES

**SWINGING ARM
BRAS OSCILLANT
SCHWINGARM
HORQUILLA OSCILLANTE**

**SHOCK ABSORBER
AMORTISSEUR
STOSSDÄMPFER
AMORTIGUADOR**

Model Modèle Typen Modelos	Spares No. No. de pièce Ersatzteil-Nr. No. de repuesto	Description	Designation	Beschreibung	Descripción	Per Set Par jeu Pr. Satz Juego de
A Group	4 05 02-0046	Nut	Écrou	Mutter	Tuerca	4
A Group	4 01 02-0522	Lockwasher	Rondelle frein	Sicherungsscheibe	Freno	2
A Group	1 02 02-1733	Washer	Rondelle	Scheibe	Arandela	2
A Group	1 01 03-1346	Lockwasher	Rondelle frein	Sicherungsscheibe	Freno	
A Group	4 09 03-1399	Bolt	Boulon	Schraube	Tornillo	2
A Group	4 01 15-0039	Washer	Rondelle	Scheibe	Arandela	2
A Group	19-5305	Rubber Sleeve	Douille, caoutchouc	Gummimuffe	Manguita de goma	4
A Group	4 05 24-0563	Nut	Écrou	Mutter	Tuerca	2
A Group	4 03 28-2080	Grease Nipple	Graisser	Schmiernippel	Engrasador	
A Group	4 01 35-0707	Split Pin	Goupille fendue	Splint	Chaveta hendida	
A Group	4 01 36-0382	Lockwasher	Rondelle frein	Sicherungsscheibe	Freno	
A Group	1 07 40-3075	Rubber Pad	Tampon caoutchouc	Gummiauflage	Cojin de goma	
A Group	1 07 42-4289	Collet	Collet	Keil	Refuerzo del cilindro	4
A Group	7 23 42-4291	Outer Shroud	Fourreau, extérieur	Hülse, aussen	Manguito, exterior	2
A Group	7 28 42-4292	Inner Shroud	Fourreau, intérieur	Hülse, innen	Manguito, interior	2
A Group (Solo)	7 28 42-4299	Spring	Ressort	Feder	Resorte	2
A Group (S/car)	7 28 42-4302	Spring	Ressort	Feder	Resorte	2
A Group	1 24 42-4340	Spindle	Arbre	Welle	Arbol	
A Group	1 11 42-4343	Nut	Écrou	Mutter	Tuerca	
A Group	1 28 42-4362	Silent bloc	Silentbloc	Gummilagerung	Silent bloc	
A Group	1 02 42-4364	Lockwasher	Rondelle frein	Sicherungsscheibe	Freno	
A Group	1 75 42-4450	Swinging Arm	Bras oscillant	Schwingarm	Horquilla oscilante	
A Group (Solo)	7 56 42-4461	Shock Absorber	Amortisseur	Stossdämpfer	Amortiguador	2
A Group (S/car)	7 56 42-4462	Shock Absorber	Amortisseur	Stossdämpfer	Amortiguador	
A Group	1 19 42-4730	Spring	Ressort	Feder	Resorte	
A Group	1 11 42-4744	Pivot Pin	Axe	Drehzapfen	Eje	
A Group	1 10 42-4745	Spacer Tube	Tube entretoise	Distanzrohr	Tubo espaciador	
A Group	1 49 42-4761	Centre Stand	Béquille centrale	Mittelständer	Muleta	
Spitfire Scrambler	1 49 42-4762	Centre Stand	Béquille centrale	Mittelständer	Muleta	
A Group	1 09 42-6040	Screw	Vis	Schraube	Tornillo	2
A Group	1 14 42-6763	Spacer Tube	Tube entretoise	Distanzrohr	Eje	2
A Group	1 10 65-4185	Bolt	Boulon	Schraube	Tornillo	2
A Group	4 07 66-2010	Bolt	Boulon	Schraube	Tornillo	
A Group	4 01 66-4707	Lockwasher	Rondelle frein	Sicherungsscheibe	Freno	2
A Group	1 01 67-4129	Washer	Rondelle	Scheibe	Arandela	2

Solo

S/car.

Solo

Sidecar

Solo

Beiwagen

Solo

Sidecar

**CLASSIC
BIKE SPARES**

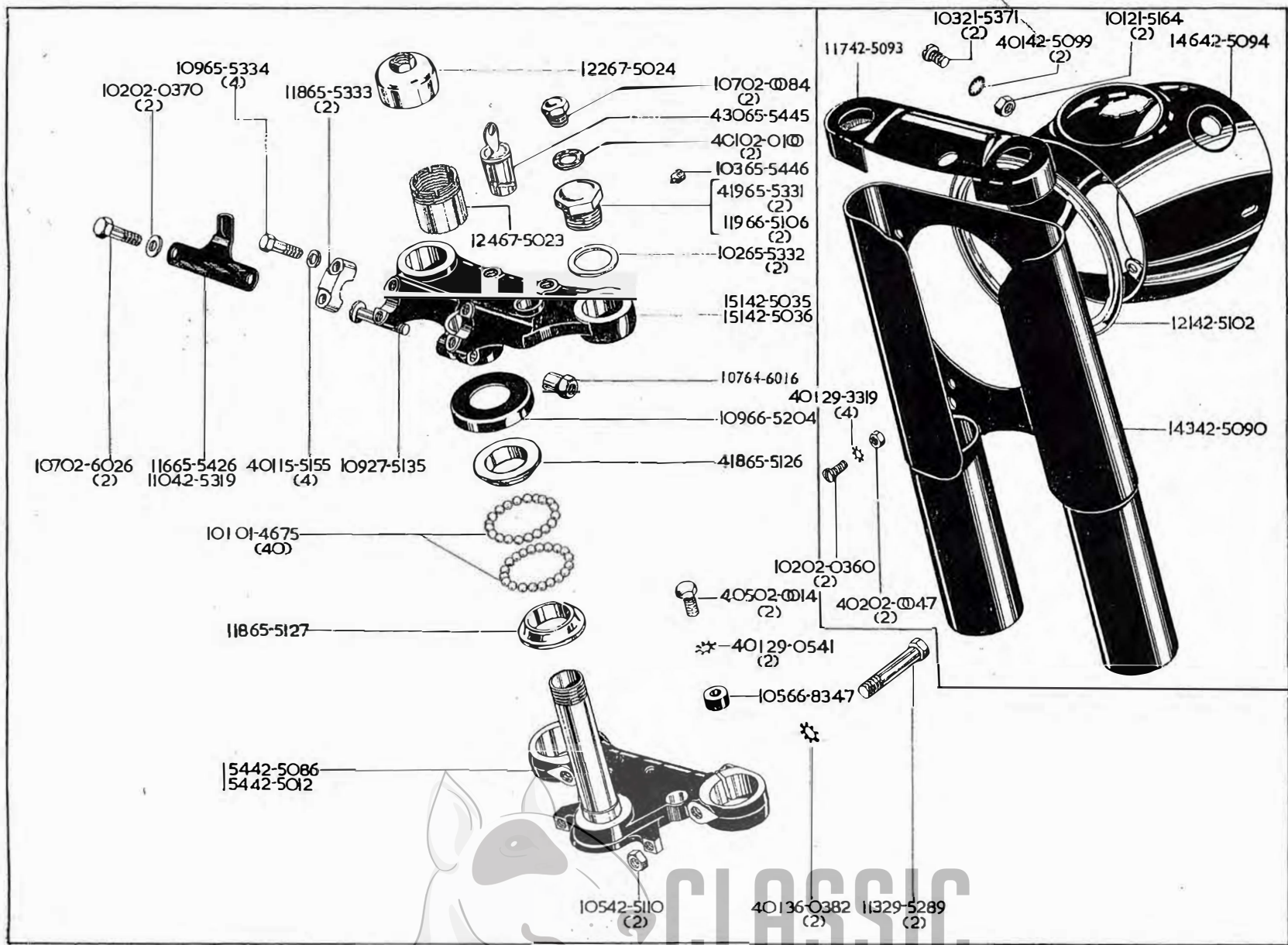

CLASSIC
BIKE SPARES

**FRONT FORK
FOURCHE AV.
VORDERGABEL
HORQUILLA DELANTERA**

Model Modèle Typen Modelos	Spares No. No. de pièce Ersatzteil-Nr. No. de repuesto	Description	Designation	Beschreibung	Descripción	Per Set Par jeu Pr. Satz Juego de
A Group	1 01 01-4675	Ball	Bille	Kugel	Bola	40
A Group	4 05 02-0014	Bolt	Boulon	Schraube	Tornillo	2
A7, A7S/S, A10	4 02 02-0047	Nut	Écrou	Mutter	Tuerca	4
500 Flash, S/S, Royal Tourist, A10S/R	1 07 02-0084**	Plug	Bouchon	Stopfen	Tapon	2
500 Flash, S/S, Royal Tourist, A10S/R	4 01 02-0100**	Sealing Washer	Bague d'étanchéité	Dichtring	Junta	2
A Group	1 02 02-0360	Screw	Vis	Schraube	Tornillo	4
A10S/R	1 02 02-0370	Washer	Rondelle	Scheibe	Arandela	2
A10S/R	1 07 02-6026	Bolt	Boulon	Schraube	Tornillo	2
A Group	4 01 15-5155	Washer	Rondelle	Scheibe	Arandela	4
A7, A7S/S, A10	1 01 21-5164	Nut	Écrou	Mutter	Tuerca	2
A7, A7S/S, A10	1 02 21-5371	Screw	Vis	Schraube	Tornillo	2
A Group	1 09 27-5135	Screw	Vis	Schraube	Tornillo	2
A Group	4 01 29-0541	Lockwasher	Rondelle frein	Sicherungsscheibe	Freno	2
A7, A7S/S, A10	4 01 29-3319	Lockwasher	Rondelle frein	Sicherungsscheibe	Freno	4
A Group	1 13 29-5289	Bolt	Boulon	Schraube	Tornillo	2
A Group	4 01 36-0382	Lockwasher	Rondelle frein	Sicherungsscheibe	Freno	2
A10S/R	1 54 42-5012	Bottom Yoke (Export)	Attache inférieur te de fourche (Export)	Unterjoch (ausfuhr)	Horqueta inferior (Exportación)	
A7, A7S/S, A10	1 51 42-5035	Top Yoke	Tête de fourche	Oberjoch	Horqueta superior	
A10S/R	1 51 42-5036*	Top Yoke (Export)	Tête de fourche (Export)	Oberjoch (ausfuhr)	Horqueta superior (Exportación)	
A Group	1 54 42-5086†	Bottom Yoke	Attache inférieur te de fourche	Unterjoch	Horqueta inferior	
A Group	1 43 42-5090	Cover	Couvercle	Schutzkappe	Tapa	
A Group	1 17 42-5093	Top Cover	Couvercle supérieur	Schutzkappe oben	Tapa superior	
A Group	1 46 42-5094	Cowl	Capotage de phare	Scheinwerferverkleidung	Capucha	
A Group	4 01 42-5099	Lockwasher	Rondelle frein	Sicherungsscheibe	Freno	2
A Group	1 21 42-5102	Support Ring	Anneau de support	Stützring	Anillo de soporte	
A Group	1 05 42-5110	Nut	Écrou	Mutter	Tuerca	2
Spitfire Scrambler	1 10 42-5319*	Bracket	Support	Verstrebung	Soporte	
A Group	1 07 64-6016	Nut	Écrou	Mutter	Tuerca	
A Group	4 18 65-5126	Top Cone	Cone supérieur	Oberkonus	Cona superior	
A Group	1 18 65-5127	Bottom Cone	Cone inférieur	Unterkonus	Cona inferior	
A Group	4 19 65-5331	Top Nut	Écrou supérieur	Obere Mutter	Tuerca superior	2
A Group	1 02 65-5332	Washer	Rondelle	Scheibe	Arandela	2
A Group	1 18 65-5333	Clip	Bride	Klammer	Grapa	2
A7, A7S/S, A10	1 09 65-5334	Bolt	Boulon	Schraube	Tornillo	4
A10S/R	1 16 65-5426	Bracket	Support	Verstrebung	Soporte	
A Group	4 30 65-5445	Lock and Key	Serrure et clef	Schloss mit Schlüssel	Cerradura y llave	
A Group	1 03 65-5446	Grub Screw	Vis sans tête	Schraube	Tornillo prisionero	
500 Flash, S/S, Royal Tourist, A10S/R	1 19 66-5106**	Top Nut	Écrou supérieur	Obere Mutter	Tuerca superior	2
A Group	1 09 66-5204	Cap	Chapeau	Abdeckkappe	Tapon	
A Group	1 05 66-8347	Collar	Bague d'arrêt	Stelling	Anillo móvil aprisionado	
A Group	1 24 67-5023	Adjuster	Système de réglage	Einstellbüchse	Tornillo de ajuste	
A Group	1 22 67-5024	Top Nut	Écrou supérieur	Obere Mutter	Tuerca superior	

*Used with Tachometer.

†Horn mounting.

**American type.

*Employée avec compte-tours.

†Support de l'avertisseur.

**Type American.

*Benutzt mit Tachometer.

†Hornhalter.

**Amerikanische Typen.

*Empleado con cuentagiros.

†Soporte para bocina.

**Tipo Americano.

CLASSIC
BIKE SPARES

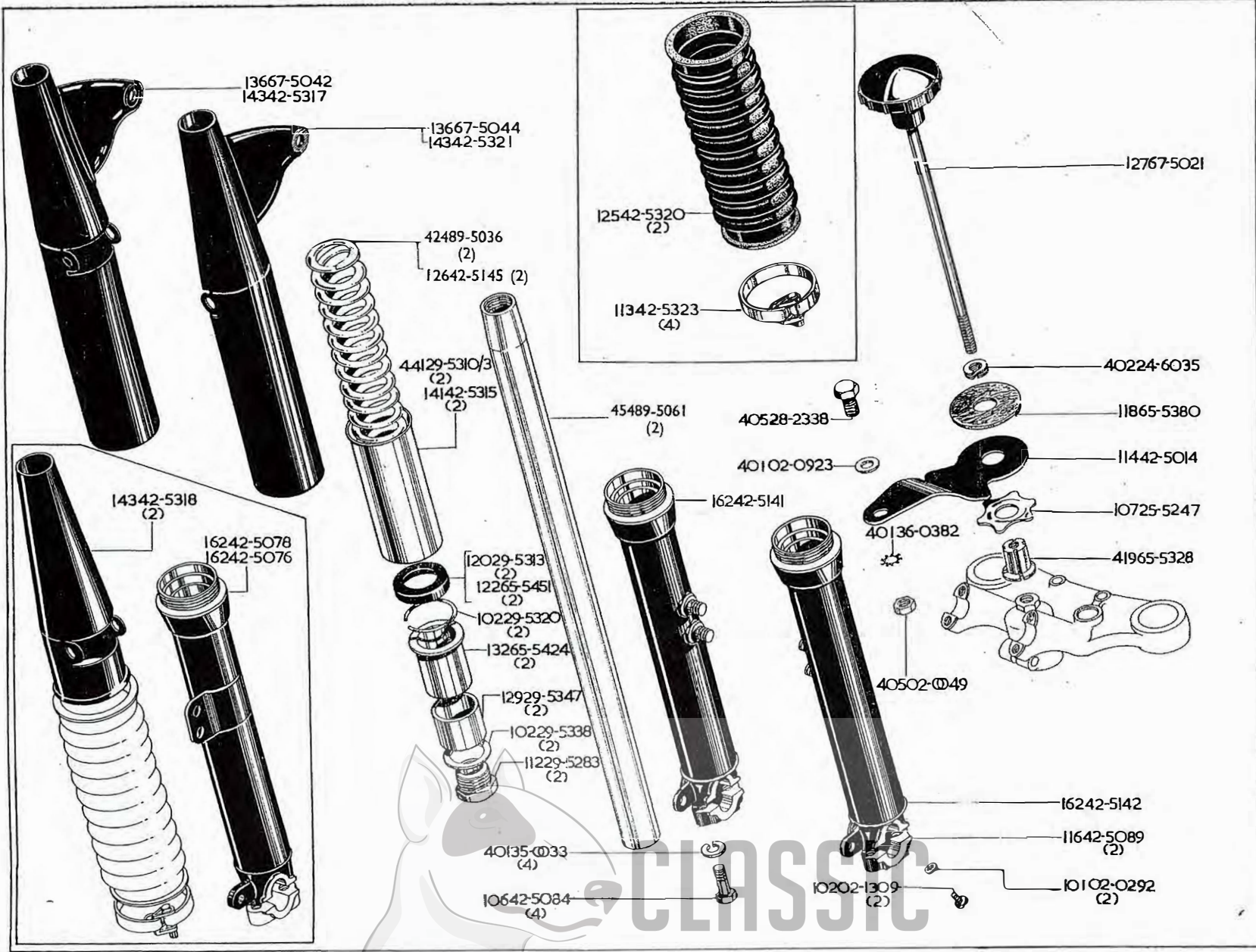

CLASSIC
 BIKE SPARES

**FRONT FORK
FOURCHE AV
VORDERGABEL
HORQUILLA DELANTERA**

Model Modèle Typen Modelos	Spares No. No. de pièce Ersatzteil-Nr. No. de repuesto	Description	Designation	Beschreibung	Descripción	Per Set Par jeu Pr. Satz Juego de
A Group	4 05 02-0049	Nut	Écrou	Mutter	Tuerca	
A Group	1 01 02-0292	Sealing Washer	Joint d'étanchéité	Dichtung	Arandela de reten	2
A Group	4 01 02-0923	Washer	Rondelle	Scheibe	Arandela	
A Group	1 02 02-1309	Plug	Bouchon	Stopfen	Tapón	2
A Group	4 02 24-6035	Lockwasher	Rondelle frein	Sicherungsscheibe	Freno	
A Group	1 07 25-5247	Star Washer	Rondelle en étoile	Sicherung	Freno	
A Group	4 05 28-2338	Bolt	Boulon	Schraube	Tornillo	
A Group	1 12 29-5283	Plug	Bouchon	Stopfen	Tapón	2
A Group	4 41 29-5310/3	Oil Seal Housing	Boiter de joint d'huile	Dichtringgehäuse	Caja reten de aceite	2
A Group	1 20 29-5313	Oil Seal	Joint d'huile	Simmerring	Reten de aceite	2
A Group	1 02 29-5320	Circlip	Arrêtoir	Sprengring	Freno	2
A Group	1 01 29-5334	Top Bush Shim (.005 in.)	Rondelle pour douille supérieur (127 mm.)	Scheibe für obere Büchse (127mm.)	Arandela para casquillo superior (127 mm.)	
A Group	1 01 29-5335	Top Bush Shim (.010 in.)	Rondelle pour douille supérieur (254 mm.)	Scheibe für obere Büchse (127mm.)	Arandela para casquillo superior (254 mm.)	
A Group	1 01 29-5336	Top Bush Shim (.020 in.)	Rondelle pour douille supérieur (508 mm.)	Scheibe für obere Büchse (508mm.)	Arandela para casquillo superior (508 mm.)	
A Group	1 01 29-5337	Top Bush Shim (.030 in.)	Rondelle pour douille supérieur (762 mm.)	Scheibe für obere Büchse (762mm.)	Arandela para casquillo superior (762 mm.)	
A Group	1 02 29-5338	Washer	Rondelle	Scheibe	Arandela	2
A Group	1 29 29-5347	Bottom Bush	Douille inférieur	Büchse unten	Casquillo inferior	2
A Group	4 01 35-0033	Lockwasher	Rondelle frein	Sicherungsscheibe	Freno	4
A Group	4 01 36-0382	Lockwasher	Rondelle frein	Sicherungsscheibe	Freno	
A Group	1 14 42-5014	Anchor Plate	Support	Ankerplatte	Soporte	
Spitfire Scrambler	1 62 42-5076*	Sliding Tube (right-hand)	Tube coulissant (droite)	Gleitrohr (rechts)	Tubo deslizando (der.)	
Spitfire Scrambler	1 62 42-5078*	Sliding Tube (left-hand)	Tube coulissant (gauche)	Gleitrohr (links)	Tubo deslizando (izq.)	
A Group	1 06 42-5084	Bolt	Boulon	Schraube	Tornillo	4
A Group	1 16 42-5089	Cap	Chapcau	Abdeckkappe	Tapón	2
A Group	1 62 42-5141	Sliding Tube (left-hand)	Tube coulissant (gauche)	Gleitrohr (links)	Tubo deslizando (izq.)	
A Group	1 62 42-5142	Sliding Tube (right-hand)	Tube coulissant (droite)	Gleitrohr (rechts)	Tubo deslizando (der.)	
A Group	1 26 42-5145	Spring (sidecar)	Ressort	Feder	Resorte	2
A10S/R, Spitfire Scrambler	1 41 42-5315*	Oil Seal Housing	Boitier de joint d'huile	Dichtringgehäuse	Caja reten de aceite	2
A10S/R	1 43 42-5317*	Sleeve (left-hand)	Douille (gauche)	Büchse (links)	Casquillo (izq.)	
Spitfire Scrambler	1 43 42-5318*	Sleeve	Douille	Büchse	Casquillo	2
A10S/R, Spitfire Scrambler	1 25 42-5320*	Tube Gaiter	Gaine de tube	Faltenbalg	Manguera de tubo	2
A10S/R	1 43 42-5321*	Sleeve (right-hand)	Douille (droite)	Büchse (rechts)	Casquillo (der.)	
A10S/R, Spitfire Scrambler	1 13 42-5323*	Clip	Bride	Klanmer	Grapa	4
A Group	4 19 65-5328	Screwed Collar	Écrou à collet	Halsmutter	Tuerca de collar	
A Group	1 18 65-5380	Washer	Rondelle	Scheibe	Arandela	
A Group	1 32 65-5424	Top Bush	Douille supérieur	Obere Büchse	Casquillo superior	2
A Group	1 22 65-5451*	Oil Seal	Joint d'huile	Simmerring	Reten de aceite	2
A Group	1 27 67-5021	Adjuster	Système de réglage	Einstellstange	Tornillo de ajuste	
A10S/R	1 36 67-5042	Sleeve (left-hand)	Douille (gauche)	Büchse (links)	Casquillo (izq.)	
A10S/R	1 36 67-5044	Sleeve (right-hand)	Douille (droite)	Büchse (rechts)	Casquillo (der.)	
A Group	4 24 89-5036	Spring (solo)	Ressort	Feder	Resorte	2
A Group	4 54 89-5061	Shaft	Arbre	Welle	Árbol	2

*American type.

*Type American.

*Amerikanische Typen.

*Tipo Americano.

CLASSIC
BIKE SPARES

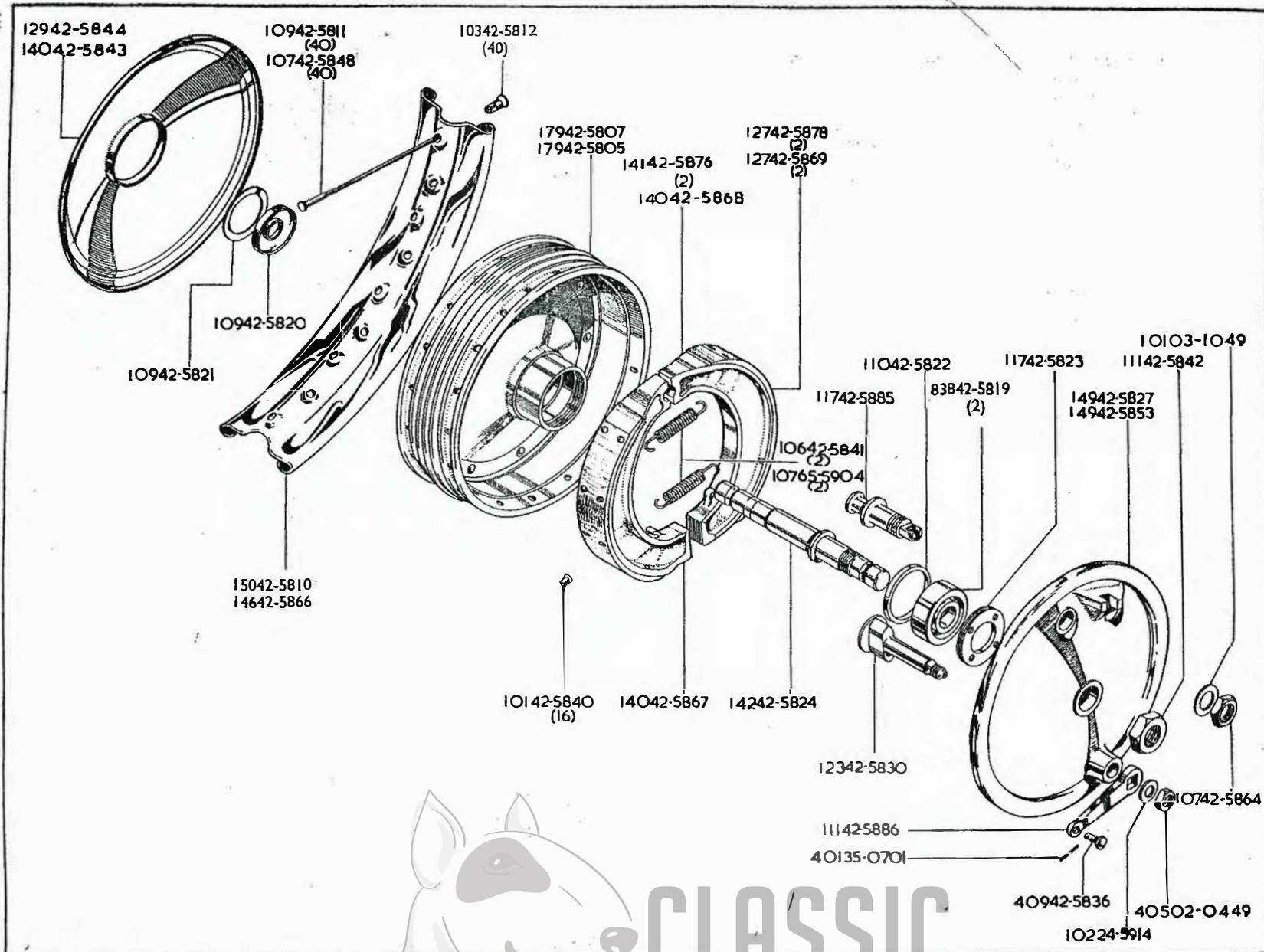

CLASSIC
BIKE SPARES

FRONT WHEEL
ROUE AV
VORDERRAD
RUEDA DELANTERA

Model Modèle Typen Modelos	Spare No. No. de pièce Ersatzteil-Nr. No. de repuesto	Description	Designation	Beschreibung	Descripción	Per Set Par jeu Pr. Satz Juego de
A Group	4 05 02-0449	Nut	Écrou	Mutter	Tuerca	
A Group	1 01 03-1049	Washer	Rondelle	Scheibe	Arandela	
A Group	1 02 24-5914	Washer	Rondelle	Scheibe	Arandela	
A Group	4 01 35-0701	Split Pin	Goupille fendue	Splint	Chaveta hendida	
A7, A7S/S, A10	1 50 42-5810	Rim	Jante	Felge	Llanta	
A7	1 09 42-5811	Spole	Rayon	Speiche	Raio	40
A Group	1 03 42-5812	Nipple	Écrou	Nippel	Tuerca	40
A Group	8 38 42-5819	Bearing	Roulement	Lager	Rolamiento	2
A Group	1 09 42-5820	Cover	Couvercle	Schutzkappe	Tapa	
A Group	1 09 42-5821	Circlip	Arrêtoir	Sprengring	Freno	
A Group	1 10 42-5822	Spacer Ring	Bague entretoise	Distanzring	Anillo espaciador	
A Group	1 17 42-5823	Retainer	Arrêtoir	Sicherung	Freno	
A Group	1 42 42-5824	Spindle	Arbre	Welle	Arbol	
A7	1 49 42-5827	Brake Back Plate	Disque de frein	Bremsscheibe	Disco de freno	
A Group	1 23 42-5830	Brake Cam	Clé de frein	Bremsschlüssel	Llave de freno	
A Group	4 09 42-5836	Pivot Pin	Axe	Bolzen	Eje	
A Group	1 01 42-5840	Rivet	Rivet	Niet	Remache	16
A7S/S, A10, A10S/R	1 06 42-5841	Spring	Ressort	Feder	Resorte	2
A Group	1 11 42-5842	Nut	Écrou	Mutter	Tuerca	
A7	1 40 42-5843	Cover	Couvercle	Schutzkappe	Tapa	
A7S/S, A10, A10S/R	1 29 42-5844	Cover	Couvercle	Schutzkappe	Tapa	
A7S/S, A10, A10S/R	1 07 42-5848	Spoke	Rayon	Speiche	Raio	40
A7S/S, A10, A10S/R	1 49 42-5853	Brake Back Plate	Disque de frein	Bremsscheibe	Disco de freno	
A Group	1 07 42-5864	Nut	Écrou	Mutter	Tuerca	
A10S/R	1 46 42-5866	Rim	Jante	Felge	Llanta	
A7S/S, A10, A10S/R	1 40 42-5867	Brake Shoe (leading)	Frein (avant)	Bremsbacke (vordere)	Zapata (delantera)	
A7S/S, A10, A10S/R	1 40 42-5868	Brake Shoe (trailing)	Frein (arrière)	Bremsbacke (hintere)	Zapata (trasera)	
A7S/S, A10, A10S/R	1 27 42-5869	Brake Lining	Garniture de frein	Bremsbelag	Guarnición	2
A7	1 41 42-5876	Brake Shoe	Frein	Bremsbacke	Zapata	2
A7	1 27 42-5878	Brake Lining	Garniture de frein	Bremsbelag	Guarnición	2
A Group	1 17 42-5885	Pivot Pin	Axe	Bolzen	Eje	
A Group	1 11 42-5886	Brake Cam Lever	Levier de came de frein	Bremsnockenhebel	Palanca de freno	
A7	1 07 65-5904	Spring	Ressort	Feder	Resorte	2

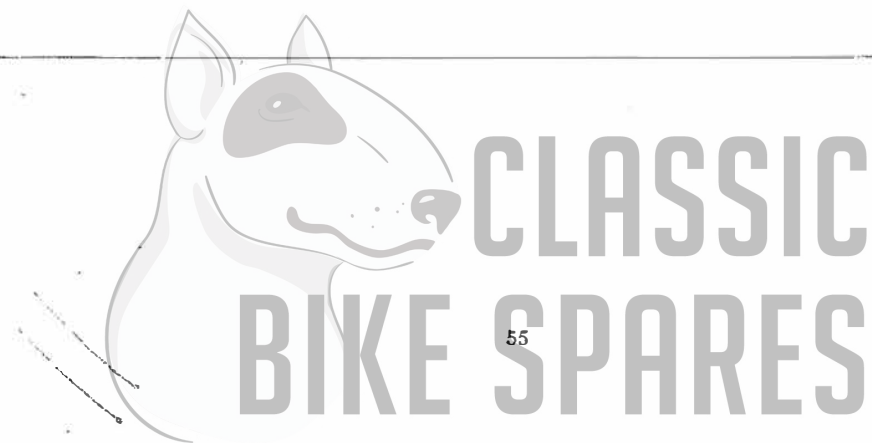

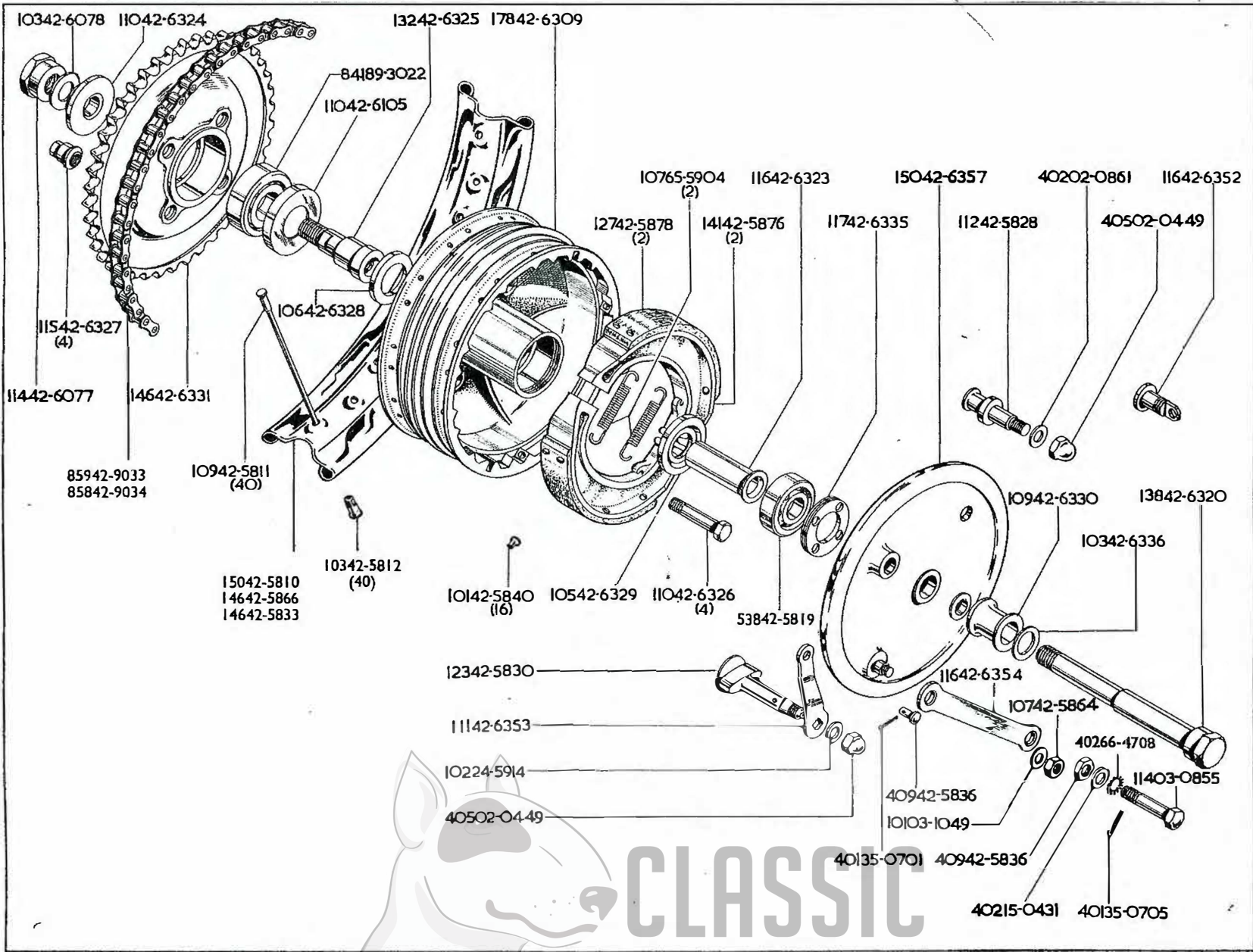

CLASSIC
 BIKE SPARES

REAR WHEEL
ROUE AR
HINTERRAD
RUEDA TRASERA

Model Modèle Typen Modelos	Spares No. No. de pièce Ersatzteil-Nr. No. de repuesto	Description	Designation	Beschreibung	Descripción	Per Set Par jeu Pr. Satz Juego de
A Group	4 05 02-0499	Nut	Écrou	Mutter	Tuerca	2
A Group	4 02 02-0861	Washer	Rondelle	Scheibe	Arandela	
A Group	1 14 03-0855	Bolt	Boulon	Schraube	Tornillo	
A Group	1 01 03-1049	Washer	Rondelle	Scheibe	Arandela	
A Group	4 02 15-0431	Washer	Rondelle	Scheibe	Arandela	
A Group	1 05 24-5860	Nut	Écrou	Mutter	Tuerca	
A Group	1 02 24-5914	Washer	Rondelle	Scheibe	Arandela	
A Group	4 01 35-0701	Split Pin	Goupille fendue	Splint	Chaveta hendida	
A Group	4 01 35-0705	Split Pin	Goupille fendue	Splint	Chaveta hendida	
A7, A7S/S, A10	1 50 42-5810	Rim	Jante	Felge	Llanta	
A Group	1 09 42-5811	Spoke	Rayon	Speiche	Raio	40
A Group	1 03 42-5812	Nipple	Écrou de rayon	Nippel	Tuerca	40
A Group	8 38 42-5819	Bearing	Roulement	Lager	Rolamiento	
A Group	1 12 42-5828	Fulcrum Pin	Goupille de butée	Drehbolzen	Espiga	
A Group	1 23 42-5830	Brake Cam	Came de frein	Bremsnocke	Llave de freno	
Spitfire Scrambler	1 46 42-5833	Rim	Jante	Felge	Llanta	
A Group	4 09 42-5836	Pivot Pin	Axe	Bolzen	Eje	
A Group	1 01 42-5840	Rivet	Rivet	Niete	Remache	16
A Group	1 07 42-5864	Nut	Écrou	Mutter	Tuerca	
A10S/R	1 46 42-5866	Rim	Jante	Felge	Llanta	
A Group	1 41 42-5876	Brake Shoe	Segment machoire de frein	Bremsbacke	Zapata	2
A Group	1 27 42-5878	Brake Lining	Garniture de frein	Bremsbelag	Guarnición	2
A Group	1 14 42-6077	Nut	Écrou	Mutter	Tuerca	
A Group	1 03 42-6078	Washer	Rondelle	Scheibe	Arandela	
A Group	1 10 42-6105	Retainer	Arrêtoir	Sicherung	Freno	
A Group	1 38 42-6320	Spindle	Arbre	Welle	Arbol	
A Group	1 16 42-6323	Distance Piece	Entretoise	Distanzrohr	Distanciadore	
A Group	1 10 42-6324	Collar	Bague d'arret	Stelling	Anillo móvil aprisionado	
A Group	1 32 42-6325	Spindle	Arbre	Welle	Arbol	
A Group	1 10 42-6326	Bolt	Boulon	Schraube	Tornillo	4
A Group	1 15 42-6327	Nut	Écrou	Mutter	Tuerca	4
A Group	1 06 42-6328	Cap	Chapeau	Abdeckkappe	Tapon	
A Group	1 05 42-6329	Collar	Bague d'arret	Stelling	Anillo móvil aprisionado	
A Group	1 09 42-6330	Sleeve	Douille	Büchse	Casquillo	
A Group	1 46 42-6331	Chain Wheel	Pignon de chaîne	Kettenrad	Piñón de cadena	
A Group	1 17 42-6335	Retainer	Arrêtoir	Sicherung	Freno	
A Group	1 03 42-6336	Washer	Rondelle	Scheibe	Arandela	
A Group	1 16 42-6352	Anchor Bolt	Boulon d'ancrage	Ankerbolzen	Tornillo de sujeción	
A Group	1 11 42-6353	Lever	Lévier	Hebel	Palanca	
A Group	1 16 42-6354	Anchor Strap	Bride d'ancrage	Ankerhalterung	Anclaje de freno	
A Group	1 50 42-6357	Anchor Plate	Support	Ankerplatte	Soporte	
A7, A7S/S (Solo)	8 59 42-9033	Chain	Chaîne	Kette	Cadena	
A10, A10S/R (S/car)	8 59 42-9033	Chain	Chaîne	Kette	Cadena	
A7, A7S/S (S/car)	8 58 42-9034	Chain	Chaîne	Kette	Cadena	
A10, A10S/R (Solo)	8 58 42-9034	Chain	Chaîne	Kette	Cadena	
Spitfire Scrambler						
A Group	1 07 65-5904	Spring	Ressort	Feder	Resorte	2
A Group	4 02 66-4708	Lockwasher	Rondelle frein	Sicherungsscheibe	Freno	
A Group	8 41 89-3022	Bearing	Roulement	Lager	Rolamiento	
		Solo	Solo	Solo	Solo	
		S/car.	Sidecar	Beiwagen	Sidecar	

CLASSIC
BIKE SPARES

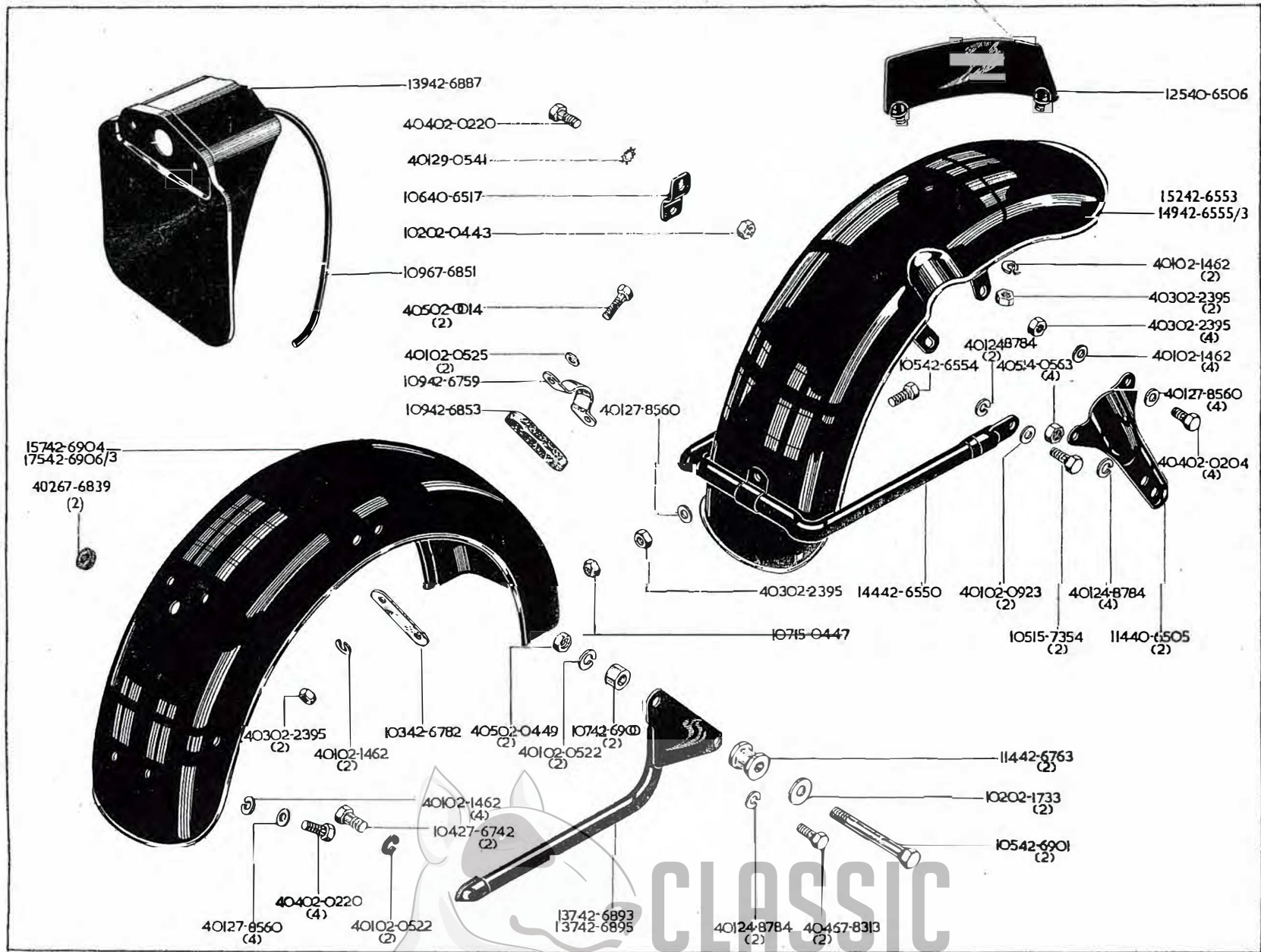

CLASSIC
 BIKE SPARES

**FRONT GUARD
GARDE-BOUE DE ROUE AV
VORDERRADSCHUTZBLECH
GUARDABARRO DELANTERA**

**REAR GUARD
GARDE-BOUE DE ROUE AR
HINTERRADSCHUTZBLECH
GUARDABARRO TRASERA**

Model Modèle Typen Modelos	Spares No. No. de pièce Ersatzteil-Nr. No. de repuesto	Description	Designation	Beschreibung	Descripción	Per Set Par jeu Pr. Satz Juego de
A Group	... 4 05 02-0014	Bolt	Boulon	Schraube	Tornillo	2
A Group	... 4 04 02-0204	Bolt	Boulon	Schraube	Tornillo	4
A Group	... 4 04 02-0220	Bolt	Boulon	Schraube	Tornillo	5
A Group	... 1 02 02-0443	Nut	Écrou	Mutter	Tuerca	
A Group	... 4 05 02-0449	Nut	Écrou	Mutter	Tuerca	2
A Group	... 4 01 02-0522	Lockwasher	Rondelle frein	Sicherungsscheibe	Freno	4
A Group	... 4 01 02-0525	Washer	Rondelle	Scheibe	Arandela	2
A Group	... 4 01 02-0923	Washer	Rondelle	Scheibe	Arandela	2
A Group	... 4 01 02-1462	Lockwasher	Rondelle frein	Sicherungsscheibe	Freno	12
A Group	... 1 02 02-1733	Washer	Rondelle	Scheibe	Arandela	2
A Group	... 4 03 02-2395	Nut	Écrou	Mutter	Tuerca	11
A Group	... 1 07 15-0447	Nut	Écrou	Mutter	Tuerca	
A Group	... 1 05 15-7354	Bolt	Boulon	Schraube	Tornillo	2
A Group	... 4 05 24-0563	Nut	Écrou	Mutter	Tuerca	4
A Group	... 4 01 24-8784	Lockwasher	Rondelle frein	Sicherungsscheibe	Freno	8
A Group	... 1 04 27-6742	Bolt	Boulon	Schraube	Tornillo	2
A Group	... 4 01 27-8560	Washer	Rondelle	Scheibe	Arandela	9
A Group	... 4 01 29-0541	Lockwasher	Rondelle frein	Sicherungsscheibe	Freno	
A Group	... 1 14 40-6505	Bracket	Support	Verstrebung	Soporte	2
A Group	... 1 25 40-6506	Number Plate	Plaque de police	Nummern	Chapa de patente	
A Group	... 1 06 40-6517	Bracket	Support	Verstrebung	Soporte	
A Group	... 1 44 42-6550	Front Stand	Beguille av	Ständer	Soporte delantera	
A10S/R	... 1 54 42-6550/3*	Front Stand	Beguille av	Ständer	Soporte delantera	
A Group	... 1 52 42-6553	Front Guard	Garde-boue de roue av	Vorderradschutzblech	Guardabarro delantera	
A Group	... 1 05 42-6554	Bolt	Boulon	Schraube	Tornillo	
A7S/S, 500 Flash	... 1 49 42-6555*	Front Guard	Garde-boue de roue av	Vorderradschutzblech	Guardabarro delantera	
A10S/R	... 1 58 42-6555/3*	Front Guard	Garde-boue de roue av	Vorderradschutzblech	Guardabarro delantera	
A Group	... 1 09 42-6759	Clip	Bride	Klammer	Grapa	
A Group	... 1 14 42-6763	Distance Piece	Entretoise	Distanzrohr	Distanciador	2
A Group	... 1 03 42-6782	Plate	Plaque	Scheibe	Placa	
A Group	... 1 09 42-6853	Rubber Pad	Tampon caoutchouc	Gummi Auflage	Cojin de goma	
A Group	... 1 39 42-6887	Number Plate	Plaque de police	Nummern	Chapa de patente	
A Group	... 1 37 42-6893	Stay (left-hand)	Tringle (gauche)	Strebe (links)	Tirante (izq.)	
A10S/R	... 1 45 42-6893/3*	Stay (left-hand)	Tringle (gauche)	Strebe (links)	Tirante (izq.)	
A10S/R	... 1 45 42-6895/3*	Stay (right-hand)	Tringle (droite)	Strebe (rechts)	Tirante (der.)	
A Group	... 1 37 42-6895	Stay (right-hand)	Tringle (droite)	Strebe (rechts)	Tirante (der.)	
A Group	... 1 07 42-6900	Distance Piece	Entretoise	Distanzrohr	Distanciador	2
A Group	... 1 05 42-6901	Bolt	Boulon	Schraube	Tornillo	2
A Group	... 1 57 42-6904	Rear Guard	Garde-boue de roue ar	Hinterradschutzblech	Guardabarro trasera	
A10S/R	... 1 75 42-6906/3*	Rear Guard	Garde-boue de roue ar	Hinterradschutzblech	Guardabarro trasera	
A Group	... 4 02 67-6839	Rubber Grommet	Viole	Gummitülle	Manguera de goma	1
A Group	... 1 09 67-6851	Rubber Moulding	Caoutchouc moulé	Profilgummi	Profil de goma	
A Group	... 4 04 67-8313	Bolt	Boulon	Schraube	Tornillo	2

*American type.

*Type American.

*Amerikanische Typen.

*Tipo Americano.

**CLASSIC
BIKE SPARES**

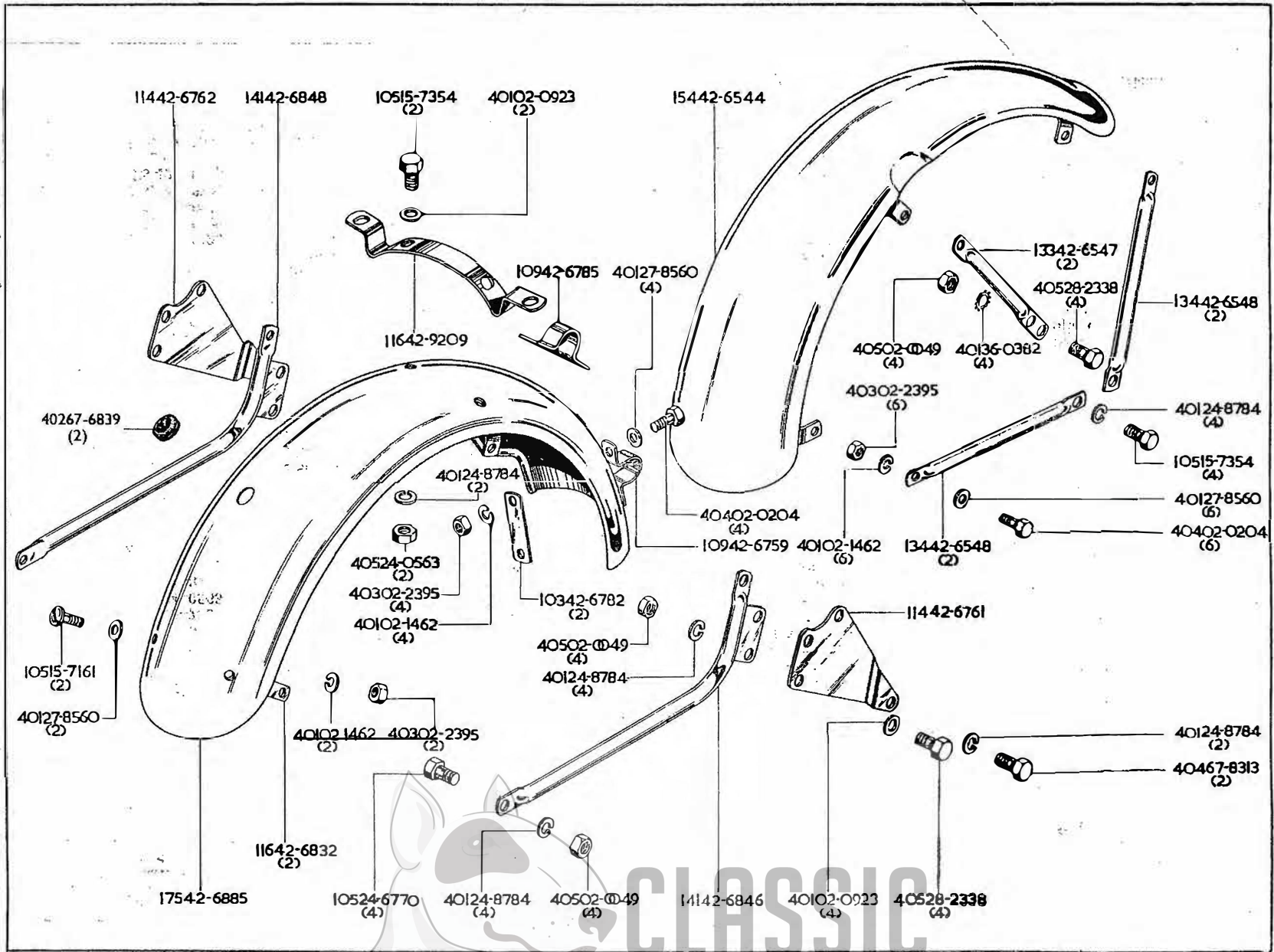

CLASSIC
 BIKE SPARES

FRONT GUARD
GARDE-BOUE DE ROUE AV
VORDERRADSCHUTZBLECH
GUARDABBRRO DELANTERA

REAR GUARD
GARDE-BOUE DE ROUE AR
HINTERRADSCHUTZBLECH
GUARABARRO TRASERA

Model Modèle Typen Modelos	Spares No. No. de pièce Ersatzteil-Nr. No. de repuesto	Description	Designation	Beschreibung	Descripción	Per Set Par jeu Pr. Satz Juego de
Spitfire Scrambler ...	4 05 02-0049	Nut	Écrou	Mutter	Tuerca	12
Spitfire Scrambler ...	4 04 02-0204	Bolt	Boulon	Schraube	Tornillo	10
Spitfire Scrambler ...	4 01 02-0923	Washer	Rondelle	Scheibe	Arandela	6
Spitfire Scrambler ...	4 01 02-1462	Lockwasher	Rondelle frein	Sicherungsscheibe	Freno	12
Spitfire Scrambler ...	4 03 02-2395	Nut	Écrou	Mutter	Tuerca	5
Spitfire Scrambler ...	1 05 15-7161	Screw	Vis	Schraube	Tornillo	2
Spitfire Scrambler ...	1 05 15-7354	Bolt	Boulon	Schraube	Tornillo	6
Spitfire Scrambler ...	4 05 24-0563	Nut	Écrou	Mutter	Tuerca	2
Spitfire Scrambler ...	1 05 24-6770	Bolt	Boulon	Schraube	Tornillo	4
Spitfire Scrambler ...	4 01 24-8784	Lockwasher	Rondelle frein	Sicherungsscheibe	Freno	16
Spitfire Scrambler ...	4 01 27-8560	Washer	Rondelle	Scheibe	Arandela	9
Spitfire Scrambler ...	4 05 28-2338	Bolt	Boulon	Schraube	Tornillo	8
Spitfire Scrambler ...	4 01 36-0382	Lockwasher	Rondelle frein	Sicherungsscheibe	Freno	4
Spitfire Scrambler ...	1 54 42-6544/3	Front Guard	Garde-boue de roue av	Vorderradschutzblech	Guardabarro delantera	
Spitfire Scrambler ...	1 33 42-6547/3	Stay (short)	Tringle (courte)	Strebe (kurz)	Tirante (corto)	2
Spitfire Scrambler ...	1 34 42-6548/3	Stay (long)	Tringle (longue)	Strebe (lang)	Tirante (largo)	4
Spitfire Scrambler ...	1 09 42-6759	Clip	Bride	Klammer	Grapa	
Spitfire Scrambler ...	1 14 42-6761	Bracket (o/s)	Support (droite)	Verstrebung (rechts)	Soporte (der.)	
Spitfire Scrambler ...	1 14 42-6762	Bracket (n/s)	Support (gauche)	Verstrebung (links)	Soporte (izq.)	
Spitfire Scrambler ...	1 03 42-6782	Back Plate	Plaque arrière	Hintere Platte	Placa trasera	2
Spitfire Scrambler ...	1 09 42-6785	Clip (top)	Bride (dessus)	Klammer (oben)	Grapa (superior)	
Spitfire Scrambler ...	1 16 42-6832	Bracket	Support	Verstrebung	Soporte	2
Spitfire Scrambler ...	1 41 42-6846/3	Stay (o/s)	Tringle (droite)	Strebe (rechts)	Tirante (der.)	
Spitfire Scrambler ...	1 41 42-6848/3	Stay (n/s)	Tringle (gauche)	Strebe (links)	Tirante (izq.)	
Spitfire Scrambler ...	1 75 42-6885/3	Rear Guard	Garde-boue de roue ar	Hinterradschutzblech	Guardabarro trasera	
Spitfire Scrambler ...	1 16 42-9209	Bracket	Support	Verstrebung	Soporte	
Spitfire Scrambler ...	4 02 67-6839	Grommet	Rondelle capuchon	Tülle	Manguera	2
Spitfire Scrambler ...	4 04 67-8313	Bolt	Boulon	Schraube	Tornillo	2



CLASSIC
BIKE SPARES

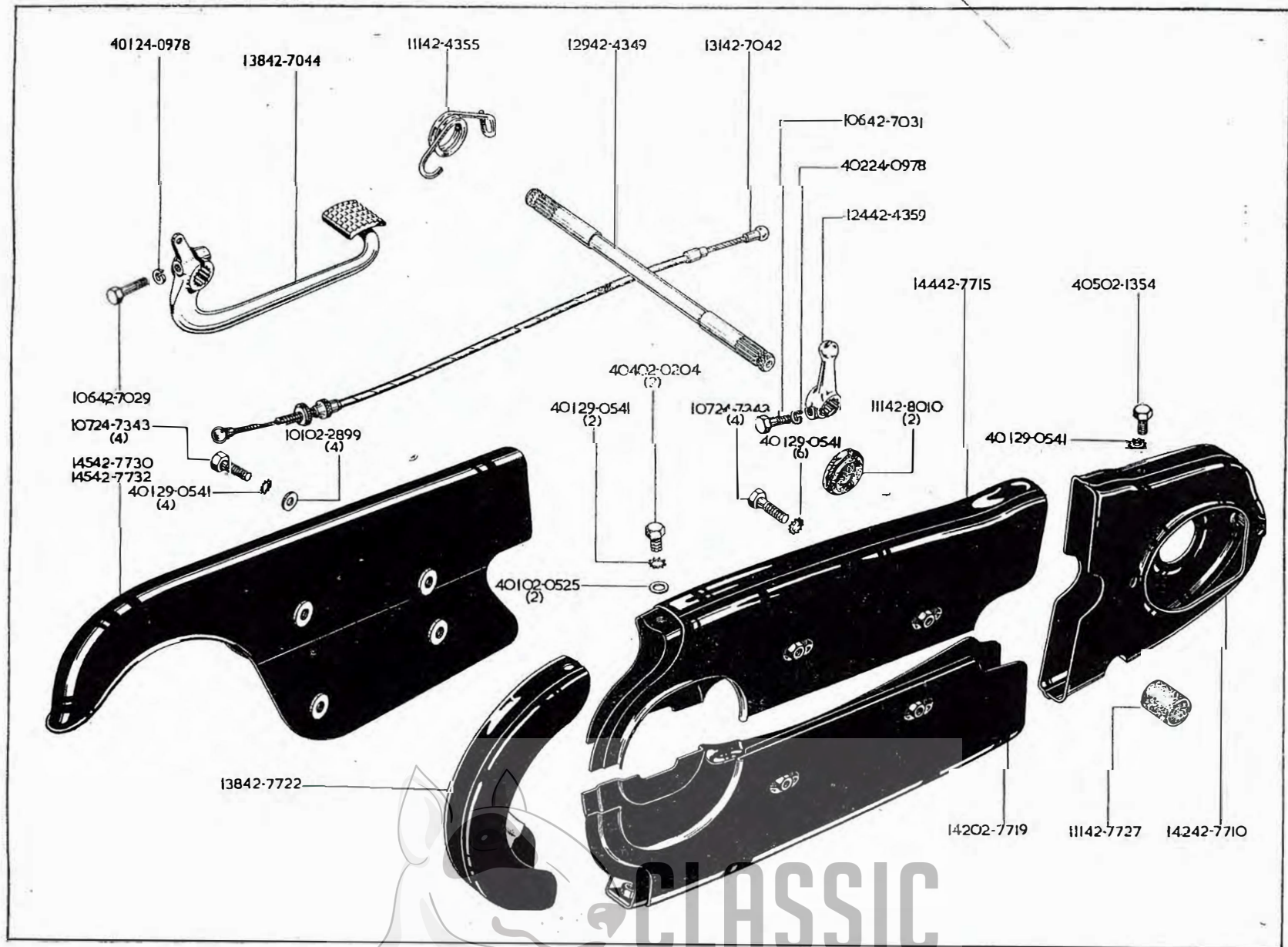

CLASSIC
 BIKE SPARES

**CHAINGUARD
CARTER DE CHAÎNE
KETTENSCHUTZ
GUARDACADENA**

**BRAKE PEDAL
PÉDALE DE FREIN
FUSSBREMSHEBEL
PEDAL DE FRENO**

Model Modèle Typen Modelos	Spares No. No. de pièce Ersatzteil-Nr. No. de repuesto	Description	Designation	Beschreibung	Descripción	Per Set Par jeu Pr. Satz Juego de
A Group	4 04 02-0204	Bolt	Boulon	Schraube	Tornillo	2
A Group	4 01 02-0525	Washer	Rondelle	Scheibe	Arandela	2
A Group	4 05 02-1354	Bolt	Boulon	Schraube	Tornillo	
A Group	1 01 02-2899	Washer	Rondelle	Scheibe	Arandela	4
A Group	4 01 24-0978	Lockwasher	Rondelle frein	Sicherungsscheibe	Freno	2
A Group	1 07 24-7343	Bolt	Schraube	Boulon	Tornillo	9
A Group	4 01 29-0541	Lockwasher	Rondelle frein	Sicherungsscheibe	Freno	13
A Group	1 29 42-4349	Spindle	Arbre	Welle	Arbol	
A Group	1 11 42-4355	Spring	Ressort	Feder	Resorte	
A Group	1 24 42-4359	Lever	Levier	Hebel	Palanca	
A Group	1 06 42-7029	Bolt	Boulon	Schraube	Tornillo	
A Group	1 06 42-7031	Bolt	Boulon	Schraube	Tornillo	
A Group	1 42 42-7039	Brake Cable	Pédale de frein	Fussbremshebel	Pedal de freno	
A Group	1 31 42-7042	Brake Pedal	Câble Bowden de commande du frein ar.	Hinteres Bremskabel	Cable Bowden para freno trasera	
Spitfire Scrambler	1 38 42-7044	Brake Pedal	Pédale de frein	Fussbremshebel	Pedal de freno	
A Group	1 42 42-7710	Chaincase Front Section	Partie avant de la carter de chaîne.	Kettenkasten-Vorderteil	Parte delantera del cárter	
A Group	1 44 42-7715	Chaincase Top Section	Partie supérieur de la carter de chaîne.	Kettenkasten-Oberteil	Parte superior del cárter	
A Group	1 42 42-7719	Chaincase Bottom Section	Partie inférieur de la carter de chaîne.	Kettenkasten-Unterteil	Parte inferior del cárter	
A Group	1 38 42-7722	Chaincase Rear Section	Partie ar de la carter de chaîne	Kettenkasten-Hinterteil	Parte trasera del cárter	
A Group	1 11 42-7727	Rubber Sleeve	Douille, caoutchouc	Gummimuffe	Manguita de goma	
A Group	1 45 42-7730	Chainguard	Carter de chaîne	Kettenschutz	Guardacadena	
Spitfire Scrambler	1 45 42-7732	Chainguard	Carter de chaîne	Kettenschutz	Guardacadena	
A Group	1 11 42-8010	Grommet	Rondelle capichon	Tülle	Manguera	2



**CLASSIC
BIKE SPARES**

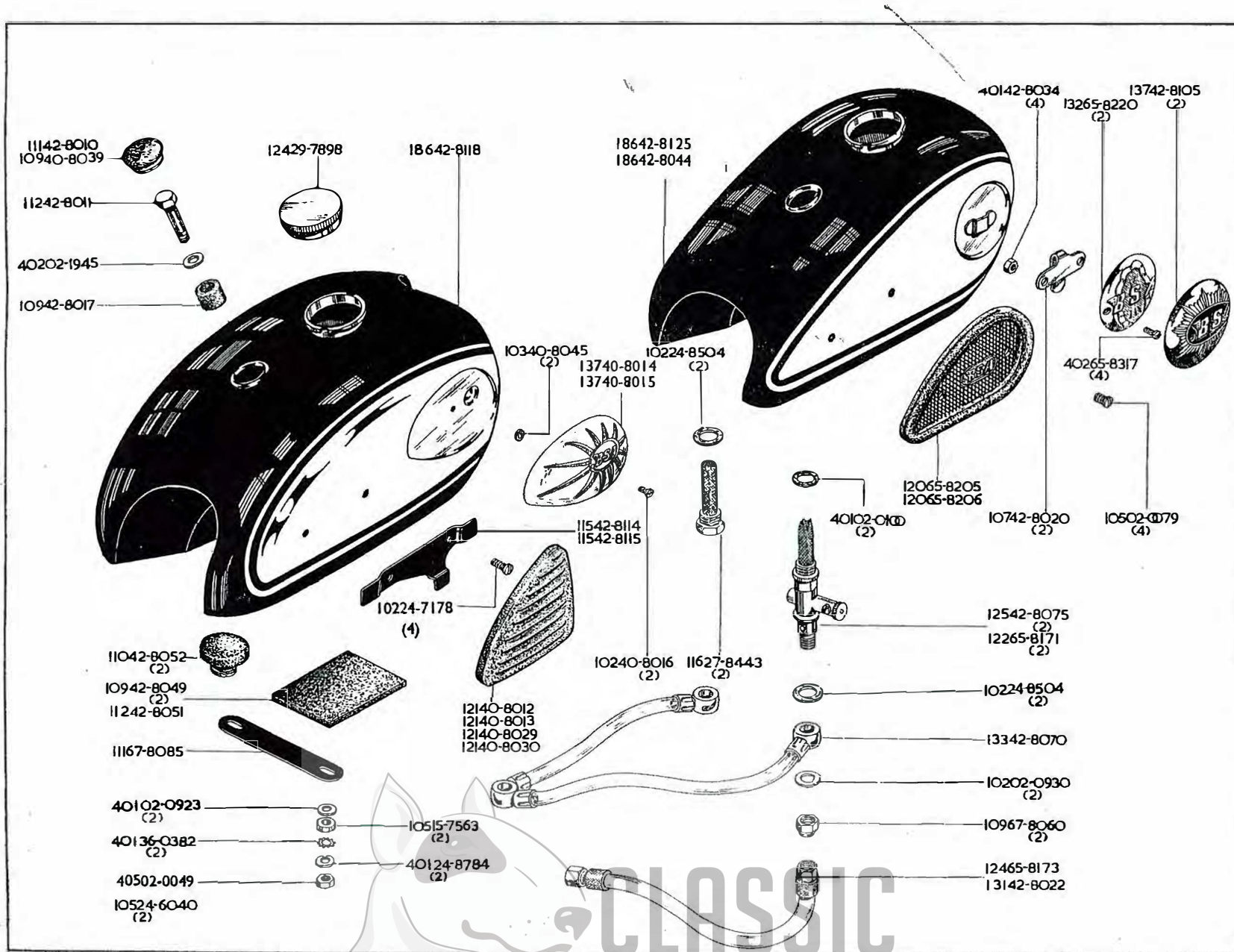

CLASSIC
 BIKE SPARES

**PETROL TANK
RESERVOIR D'ESSENCE
BENZINTANK
DEPOSITO DE COMBUSTIBLE**

Model Modèle Typen Modelos	Spares No. No. de pièce Ersatzteil-Nr. No. de repuesto	Description	Designation	Beschreibung	Descripción	Per Set Par jeu Pr. Satz Juego de
A Group ...	4 05 02-0049	Nut	Écrou	Mutter	Tuerca	2
A Group ...	1 05 02-0079	Screw	Vis	Schraube	Tornillo	4
A Group ...	4 01 02-0100	Sealing Washer	Joint d'étanchéité	Dichtung	Arandela de reten	2
A Group ...	4 01 02-0923	Washer	Rondelle	Scheibe	Arandela	2
A10S/R ...	1 02 02-0930†	Sealing Washer	Joint d'étanchéité	Dichtung	Arandela de reten	2
A Group ...	4 02 02-1945	Washer	Rondelle	Scheibe	Arandela	
A Group ...	1 05 15-7563	Distance Piece	Entretoise	Distanzrohr	Distanciador	2
A Group ...	1 05 24-6040	Nut	Écrou	Mutter	Tuerca	2
A Group ...	1 02 24-7178	Screw	Vis	Schraube	Tornillo	4
A Group ...	1 02 24-8504	Washer	Rondelle	Scheibe	Arandela	2
A Group ...	4 01 24-8784	Lockwasher	Rondelle frein	Sicherungsscheibe	Freno	2
A10S/R ...	1 16 27-8443†	Filter	Filter	Filter	Filtro	2
A Group ...	1 24 29-7898	Cap	Chapeau	Abdeckkappe	Tapon	
A Group ...	4 01 36-0382	Lockwasher	Rondelle frein	Sicherungsscheibe	Freno	2
A Group ...	1 21 40-8012	Rubber Pad (left-hand)	Tampon caoutchouc (gauche)	Gummiauflage (links)	Cojin de goma (izq.)	
A Group ...	1 21 40-8013	Rubber Pad (right-hand)	Tampon caoutchouc (droite)	Gummiauflage (rechts)	Cojin de goma (der.)	
A Group ...	1 37 40-8014	Name Plate (right-hand)	Écusson (droite)	Typenzeichen (rechts)	Placa (der.)	
A Group ...	1 37 40-8015	Name Plate (left-hand)	Écusson (gauche)	Typenzeichen (links)	Placa (izq.)	
A Group ...	1 02 40-8016	Screw	Vis	Schraube	Tornillo	2
500 Flash, A7S/S, Road Tourist, A10S/R	1 21 40-8029*	Rubber Pad (right-hand)	Tampon caoutchouc (droite)	Gummiauflage (rechts)	Cojin de goma (der.)	
500 Flash, A7S/S, Road Tourist, A10S/R	1 21 40-8030*	Rubber Pad (left-hand)	Tampon caoutchouc (gauche)	Gummiauflage (links)	Cojin de goma (izq.)	
A Group ...	1 09 40-8039	Rubber Grommet	Virole	Gummitülle	Manguera de goma	
A Group ...	1 03 40-8045	Washer	Rondelle	Scheibe	Arandela	2
A Group ...	**1 37 41-8004	Badge, Petrol Tank (2 gallon).	Écusson, réservoir d'essence (9.09 litres).	Typenzeichen, Benzintank (9.09 litres).	Placa, deposito de combustible (9.09 litres).	2
500 Flash, A7S/S, Road Tourist, A10S/R	1 11 42-8010*	Rubber Grommet	Virole	Gummitülle	Manguera de goma	
A Group ...	1 12 42-8011	Bolt	Boulon	Schraube	Tornillo	
A Group ...	1 09 42-8017	Rubber Sleeve	Douille moulé	Gummimuffe	Manguita de goma	
A Group ...	1 07 42-8020	Clip	Bride	Klammer	Grapa	2
A10S/R ...	1 31 42-8022†	Petrol Pipe (long) *American Type †For T.T. Carburetter	Tuyauterie d'essence (longue) *Type American †Pour carburateur T.T.	Benzinleitung (lang) *Amerikanische Typen †für T.T. Vergaser	Tubo de benzina (long) *Tipo Americano †Para carburador T.T.	
	**Fitted on and after Frame No. GA7-11101		Montée depuis cadre numero GA7-11101	Nach Rahmennummer GA7-11101 montiert	Montada despnes de cuadro numero GA7-11101	

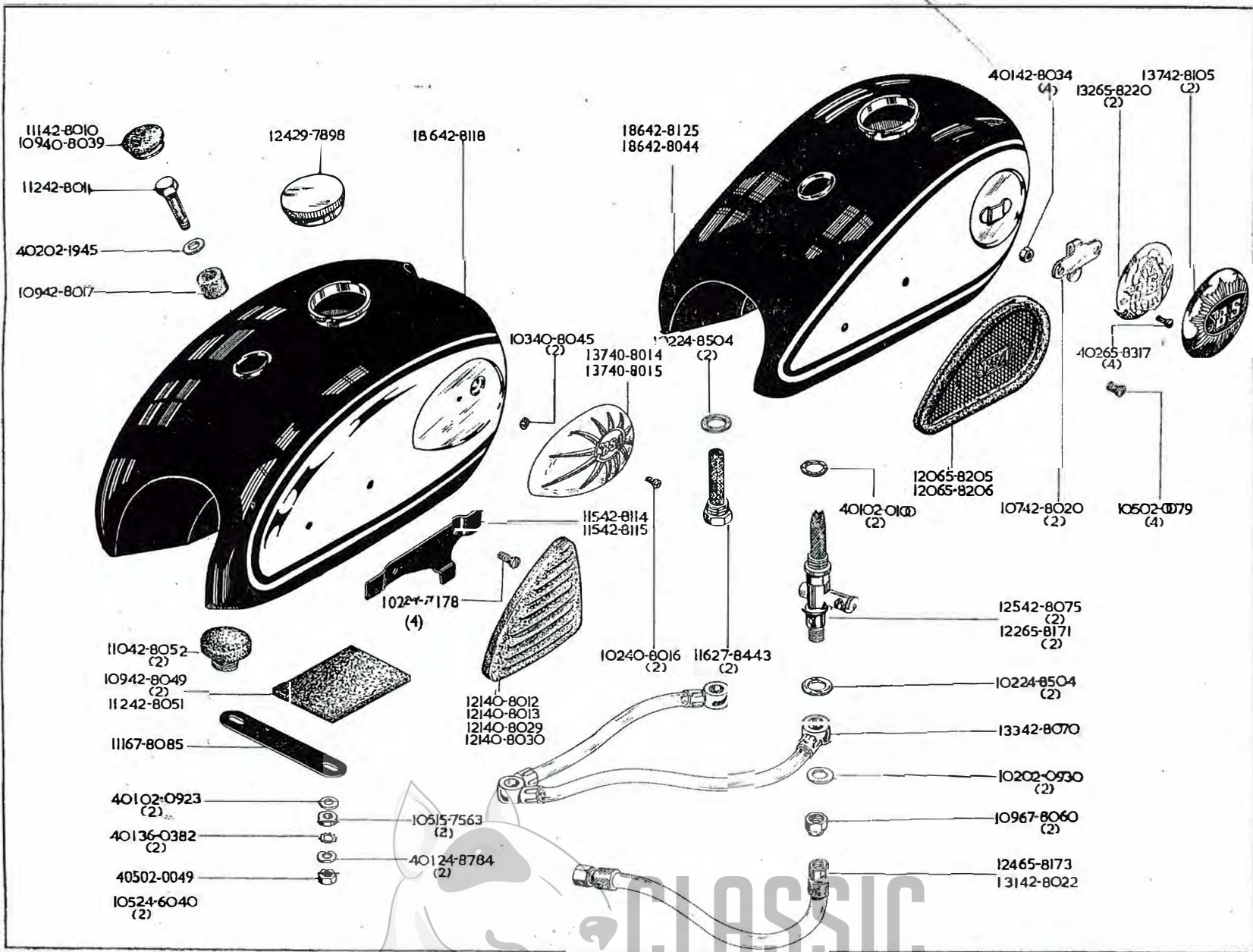

CLASSIC
 66
 BIKE SPARES

**PETROL TANK
RESERVOIR D'ESSENCE
BENZINTANK
DEPOSITO DE COMBUSTIBLE**

Model Modèle Typen Modelos	Spares No. No. de pièce Ersatzteil-Nr. No. de repuesto	Description	Designation	Beschreibung	Descripción	Per Set Par jeu Pr. Satz Juego de
A Group ...	4 01 42-8034	Nut	Écrou	Mutter	Tuerca	4
A7, A10, A10S/R ...	1 86 42-8043	Petrol Tank (2 gallon)	Réservoir d'essence (9.09 litres)	Benzintank (9.09 Liter)	Deposito de combustible (9.09 litres)	
A7S/S ...	1 86 42-8044	Petrol Tank (2 gallon)	Réservoir d'essence (9.09 litres)	Benzintank (9.09 Liter)	Deposito de combustible (9.09 litres)	
A Group ...	1 09 42-8049	Rubber Pad (front)	Tampon caoutchouc (av)	Gummiaufilage vordere	Cojin de goma (delantera)	2
A Group ...	1 12 42-8051	Rubber Pad (rear)	Tampon caoutchouc (arrière)	Gummiaufilage hintere	Cojin de goma (trasera)	
A Group ...	1 10 42-8052	Rubber Buffer	Butée caoutchouc	Gummipuffer	Tope de goma	2
A Group ...	1 33 42-8070	Petrol Pipe	Tuyauterie d'essence	Benzinleitung	Tubo de benzina	
A Group ...	1 25 42-8075	Petrol Tap and Filter	Robinet à essence et filtre	Benzinhahn und Filler	Grifo de benzina y filtro	2
A7S/S ...	1 37 42-8105	Name Plate (2 gallon)	Ecusson (9.09 litres)	Typenzeichen (9.09 Liter)	Placa (9.09 litres)	
A Group ...	1 15 42-8114	Bracket (left-hand)	Support (gauche)	Verstrebung (links)	Soporte (izq.)	
A Group ...	1 15 42-8115	Bracket (right-hand)	Support (droite)	Verstrebung (rechts)	Soporte (der.)	
A Group ...	1 86 42-8118	Petrol Tank (4 gallon)	Réservoir d'essence (18.18 litres)	Benzintank (18.18 Liter)	Deposito de combustible (18.18 litres)	
A Group ...	1 86 42-8125	Petrol Tank (2 gallon)	Réservoir d'essence (9.09 litres)	Benzintank (9.09 Liter)	Deposito de combustible (9.09 litres)	
A10S/R ...	1 22 65-8171†	Petrol Tap	Robinet à essence	Benzinhahn	Grifo de benzina	2
A10S/R ...	1 24 65-8173†	Petrol Pipe (short)	Tuyauterie d'essence (courte)	Benzinleitung (kurz)	Tubo de benzina (corto)	
A Group ...	1 20 65-8205	Rubber Pad (right-hand)	Tampon caoutchouc (droite)	Gummiaufilage (rechts)	Cojin de goma (der.)	
A Group ...	1 20 65-8206	Rubber Pad (left-hand)	Tampon caoutchouc (gauche)	Gummiaufilage (links)	Cojin de goma (izq.)	
A7, A10, A10S/R ...	1 32 65-8220	Name Plate	Ecusson	Typenzeichen	Placa	2
A Group ...	4 02 65-8317	Screw	Vis	Schraube	Tornillo	4
A Group ...	1 09 67-8060	Nut	Écrou	Mutter	Tuerca	2
A Group ...	1 11 67-8085	Plate (2 gallon, 4 gallon) *American Type †For T.T. Carburetter	Plaque (9.09, 18.18 litres) *Type American †Pour carburateur T.T.	Scheibe (9.09, 18.18 Liter) *Amerikanische Typen †für T.T. Vergaser	Placa (9.09, 18.18 litres) *Tipo Americano †Para carburador T.T.	

Fitted on and after Frame No GA7-11101

Montée depuis cadre numero
GA7-11101

Nach Rahmennummer GA7-11101
montiert

Montada despues de cuadro numero
GA7-11101

**CLASSIC
BIKE SPARES**

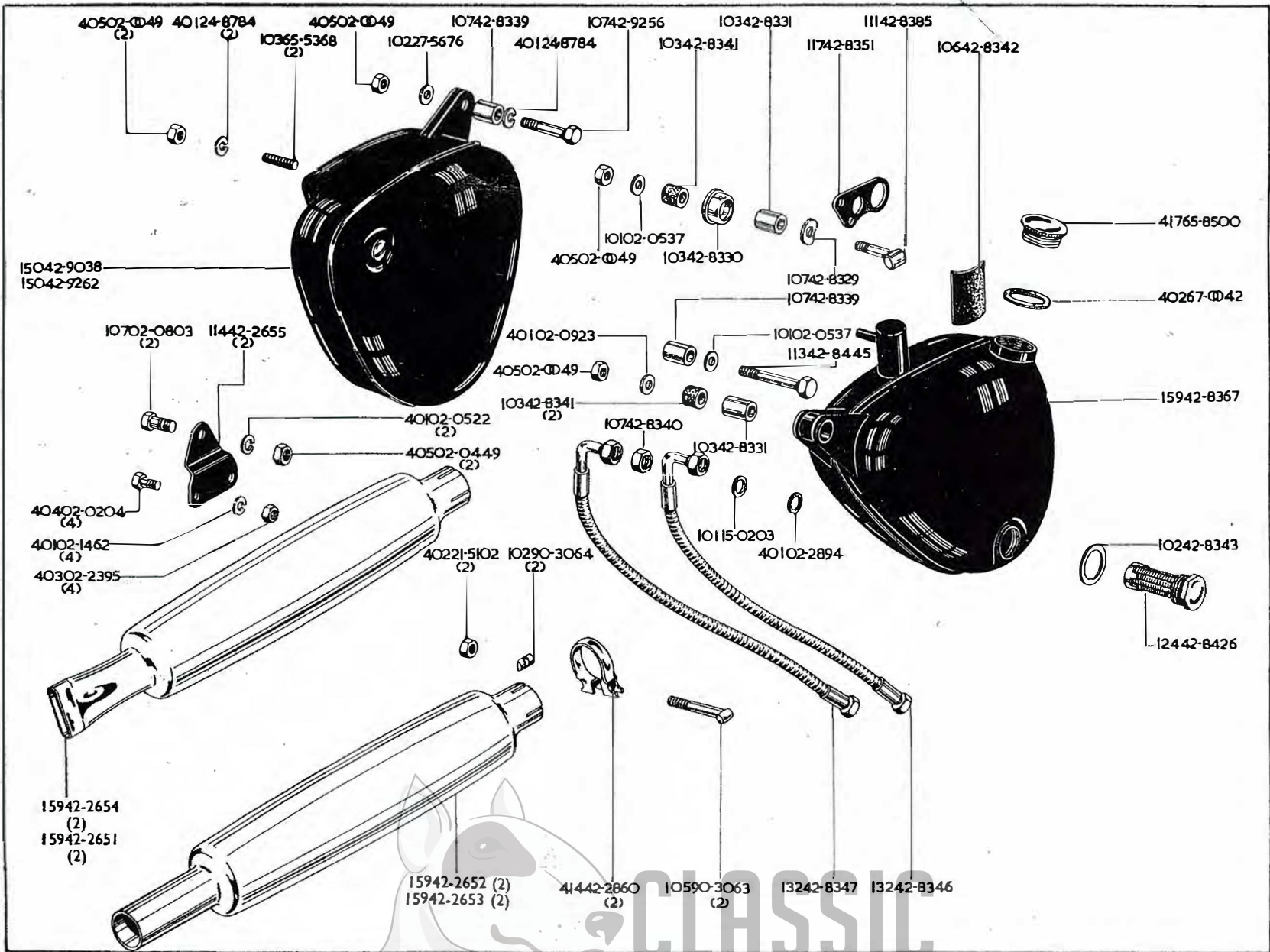

CLASSIC
 BIKE SPARES

**OIL TANK
RESERVOIR D'HUILE
ÖLTANK
DEPOSITO DE ACEITE**

**TOOL BOX
BOÎTE À OUTILS
WERKZEUGKASTEN
CAJA DE HERRAMIENTOS**

**SILENCER
SILENCIEUX
SCHALLDÄMPFER
SILENCIADOR**

Model Modèle Typen Modelos	Spare No. No. de pièce Ersatzteil-Nr. No. de repuesto	Description	Designation	Beschreibung	Descripción	Per Set Par jeu Pr. Satz Juego de
A Group	4 05 02-0049	Nut	Ecrou	Mutter	Tuerca	5
A Group	4 04 02-0204	Bolt	Boulon	Schraube	Tornillo	4
A Group	4 05 02-0449	Nut	Ecrou	Mutter	Tuerca	
A Group	4 01 02-0522	Lockwasher	Rondelle frein	Sicherungsscheibe	Freno	2
A Group	1 01 02-0537	Washer	Rondelle	Scheibe	Arandela	
A Group	1 07 02-0803	Bolt	Boulon	Schraube	Tornillo	
A Group	4 01 02-0923	Washer	Rondelle	Scheibe	Arandela	
A Group	4 01 02-1462	Lockwasher	Rondelle frein	Sicherungsscheibe	Freno	4
A Group	4 03 02-2395	Nut	Ecrou	Mutter	Tuerca	
A Group	4 01 02-2894	Sealing Washer	Joint d'étanchéité	Dichtung	Arandela de reten	
A Group	1 01 15-0203	Washer	Rondelle	Scheibe	Arandela	
A Group	4 02 21-5102	Nut	Ecrou	Mutter	Tuerca	
A Group	4 01 24-8784	Lockwasher	Rondelle frein	Sicherungsscheibe	Freno	
A Group	1 02 27-5676	Washer	Rondelle	Scheibe	Arandela	
A Group	1 59 42-2651	Silencer complete	Silencieux complet	Schalldämpfer komplett	Silenciador completa	2
A Group	1 59 42-2652	Silencer complete	Silencieux complet	Schalldämpfer komplett	Silenciador completa	2
A10S/R	1 59 42-2653	Silencer complete (Export)	Silencieux complet (Export)	Schalldämpfer komplett (Ausfuhr)	Silenciador completa (Exportación)	2
A10S/R	1 59 42-2654	Silencer complete (Export)	Silencieux complet (Export)	Schalldämpfer komplett (Ausfuhr)	Silenciador completa (Exportación)	2
A Group	1 14 42-2655	Bracket	Support	Verstrebung	Soporte	2
A Group	4 14 42-2860	Clip	Bride	Klammer	Grapa	
A Group	1 07 42-8329	Saddle Washer	Rondelle de selles	Sattelscheibe	Arandela para sillín	
A Group	1 03 42-8330	Cup	Cuvette	Schale	Copa	
A Group	1 03 42-8331	Distance Piece	Entretoise	Distanzrohr	Distanciador	2
A Group	1 07 42-8339	Distance Piece	Entretoise	Distanzrohr	Distanciador	2
A Group	1 07 42-8340	Union Nut	Ecrou de raccord	Mutter	Tuerca	
A Group	1 03 42-8341	Rubber Buffer	Butée caoutchouc	Gummitauflage	Cojín de goma	3
A Group	1 06 42-8342	Rubber Pad	Caoutchouc tampon	Gummitauflage	Cojín de goma	
A Group	1 02 42-8343	Sealing Washer	Joint d'étanchéité	Dichtung	Arandela de reten	
A Group	1 32 42-8346	Oil Feed Pipe	Tuyauterie d'alimentation d'huile	Ölzufuhrleitung	Tubo de alimentación de aceite	
A Group	1 32 42-8347	Oil Return Pipe	Tuyauterie de retour d'huile	Ölrücklaufleitung	Tubo de retorno de aceite	
A Group	1 17 42-8351	Bracket	Support	Verstrebung	Soporte	
A Group	1 59 42-8367	Oil Tank	Réservoir d'huile	Öltank	Deposito de aceite	
A Group	1 11 42-8385	Bolt	Boulon	Schraube	Tornillo	
A Group	1 24 42-8426	Oil Tank Filter	Filtre du réservoir à huile.	Öltankfilter	Filtro del depósito de aceite	
A Group	1 13 42-8445	Bolt	Boulon	Schraube	Tornillo	
A Group	1 50 42-9038	Toolbox	Boîte à outils	Werkzeugkasten	Caja de herramientas	
A Group	1 07 42-9256†	Bolt	Boulon	Schraube	Tornillo	
A Group	1 50 42-9262†	Toolbox	Boîte à outils	Werkzeugkasten	Caja de herramientas	
A Group	1 03 65-5368	Stud	Goujon	Stehbolzen	Esparago	2
A Group	4 17 65-8500	Filler Cap	Bouchon de remplissage	Verschlusskappe	Tapá	
A Group	4 02 67-0042	Sealing Washer	Joint d'étanchéité	Dichtung	Arandela de reten	
A Group	1 05 90-3063	Bolt	Boulon	Schraube	Tornillo	
A Group	1 02 90-3064	Saddle Washer	Rondelle de selles	Sattelscheibe	Arandela para sillín	

CLASSIC
BIKE SPARES

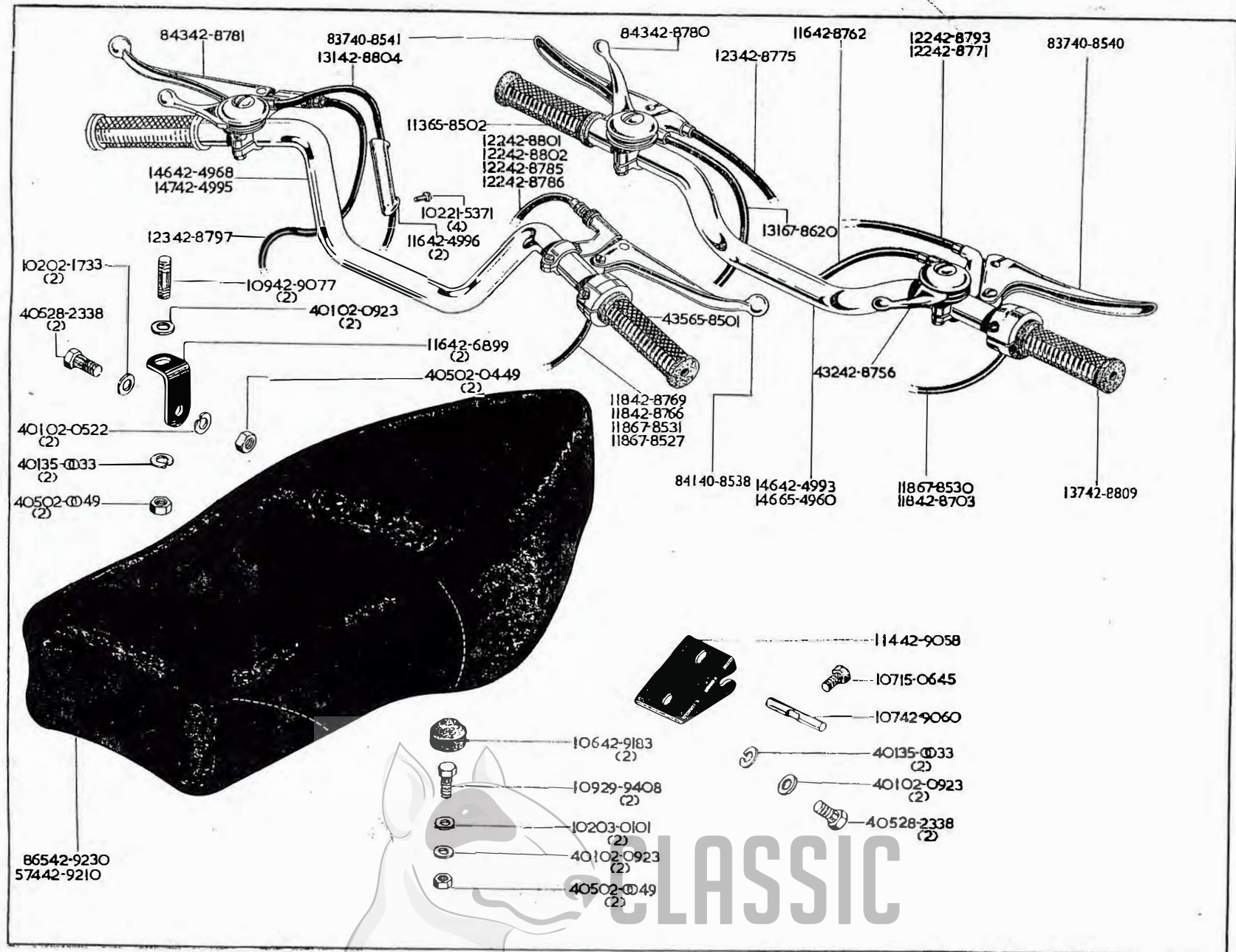

CLASSIC
 BIKE SPARES

**HANDLEBAR
GUIDON
LENKER
MANILLAR**

**DUAL SEAT
SELLE DOUBLE
DOPPELSITZ
ASIEN TO DOBLE**

Model Modèle Typen Modelos	Spares No. No. de pièce Ersatzteil-Nr. No. de repuesto	Description	Designation	Beschreibung	Descripción	Per Set Par jeu Pr. Satz Juego de
A Group	4 05 02-0049	Nut	Écrou	Mutter	Tuerca	4
A Group	4 05 02-0449	Nut	Écrou	Mutter	Tuerca	2
A Group	4 01 42-0522	Lockwasher	Rondelle frein	Sicherungsscheibe	Freno	2
A Group	4 01 02-0923	Washer	Rondelle	Scheibe	Arandela	6
A Group	1 02 02-1733	Washer	Rondelle	Scheibe	Arandela	2
A Group	1 02 03-0101	Washer	Rondelle	Scheibe	Arandela	2
500 Flash, A7S/S, Royal Tourist, A10S/R, Spit- fire Scrambler	1 02 21-5371*	Screw	Vis	Schraube	Tornillo	4
A Group	4 05 28-2338	Bolt	Boulon	Schraube	Tornillo	4
A Group	1 09 29-9408	Bolt	Boulon	Schraube	Tornillo	2
A Group	4 01 35-0033	Lockwasher	Rondelle frein	Sicherungsscheibe	Freno	4
Spitfire Scrambler ...	8 41 40-8538	Brake Lever	Levier de came de frein	Bremsnockenhebel	Palanca de freno	
A Group	8 37 40-8540	Brake Lever	Levier de came de frein	Bremsnockenhebel	Palanca de freno	
A7, A10	8 37 40-8541	Clutch Lever	Levier d'embrayage	Kupplungshebel	Palanca del embrague	
A Group	1 46 42-4968	Handlebar (Western)	Guidon (type American)	Lenker (Amerikanische Typen)	Manillar (tipo Americano)	
Spitfire Scrambler ...	1 46 42-4993*	Handlebar	Guidon	Lenker	Manillar	
500 Flash, A7S/S, Royal Tourist, A10S/R, Spit- fire Scrambler	1 47 42-4995*	Handlebar (Western)	Guidon (type American)	Lenker (Amerikanische Typen)	Manillar (tipo Americano)	
500 Flash, A7S/S, Royal Tourist, A10S/R, Spit- fire Scrambler	1 16 42-4996*	Guide	Guide	Führung	Guia	2
A Group	1 16 42-6899	Bracket	Support	Verstrebung	Soporte	2
A10S/R	1 18 42-8703†	Throttle Cable	Commande des gaz	Gaszug	Cable Bowden para acelerado	
A Group	4 32 42-8756	Air Control Lever	Levier pour la manette d'air	Lufthebel	Palanca para la manecilla de aire	
A Group	1 16 42-8762	Air Control Cable	Cable pour la manette d'air	Seilzug für Luft	Cable para la manecilla de aire	
Spitfire Scrambler ...	1 18 42-8766	Throttle Cable	Commande des gaz	Gaszug	Cable Bowden para acelerador	

*American type.

†For T.T. Carburetter and
Standard Handlebar.

**For Western Handlebar.

††For T.T. Carburetter and
Western Handlebar.

*†For Monobloc Carburetter.

*Type American.

†Pour carburateur T.T. et
guidon normal.

**Pour guidon type American.

††Pour carburateur T.T. et
guidon type American.

*†Pour carburateur monobloc.

*Amerikanisch Typen.

†für T.T. Vergaser und
normalen Lenker.

**für Lenker des Amerikanische
Typen.

††für Vergaser und Lenker
Amerikanische Typen.

*†für Monobloc Vergaser.

*Tipo Americano.

†Para carburador T.T. y
manillar normal.

**Para manillar tipo Americano.

††Para carburador T.T. y
manillar tipo Americano.

*†Para carburador monobloc.

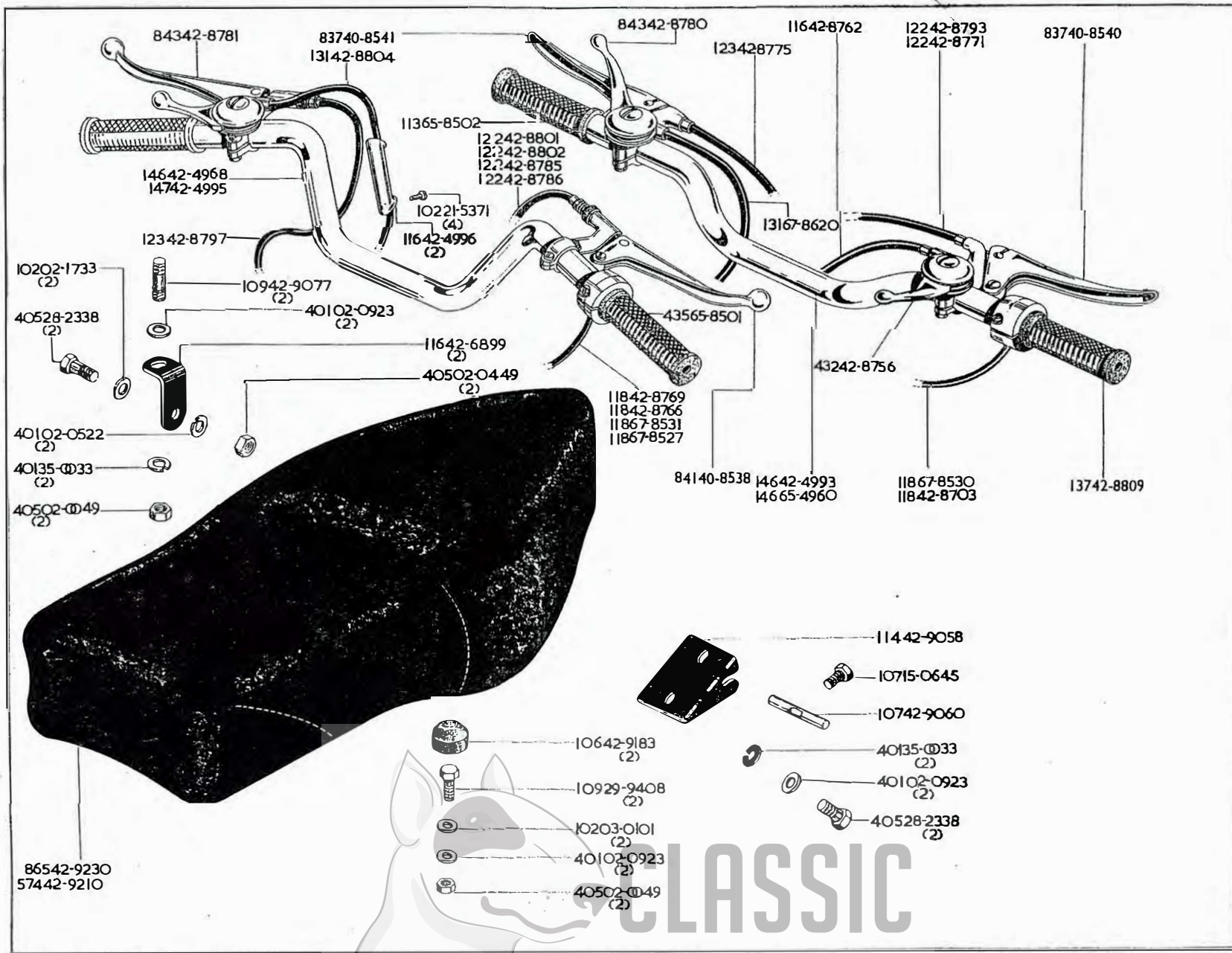

CLASSIC BIKE SPARES

**HANDLEBAR
GUIDON
LENKER
MANILLAR**

**DUAL SEAT
STELLE DOUBLE
DOPPELSITZ
ASIEN TO DOBLE**

Model Modèle Typen Modelos	Spares No. No. de pièce Ersatzteil-Nr. No. de repuesto	Description	Designation	Beschreibung	Descripción	Per Set Par jeu Pr. Satz Juego de
Royal Tourist ...	1 18 42-8769*	Throttle Cable	Comande des gaz	Gaszug	Cable Bowden para acelerador	
A7S/S, A10, A10S/R	1 22 42-8771	Front Brake Cable	Cable de commande du frein avant	Vorderradbrenskabel	Cable Bowden para freno delantera	
A Group ...	1 23 42-8775	Clutch Cable	Cable de commande de l'embrayage	Kupplungskabel	Cable Bowden para embrague	
A7S/S, A10S/R ...	8 43 42-8780	Clutch and Magneto Lever	Levier d'embrayage et magneto	Kupplungs-und Zündungshebel	Palanca del embrague y magneto	
Spitfire Scrambler ...	8 43 42-8781	Clutch and Magneto Lever	Levier d'embrayage et magneto	Kupplungs-und Zündungshebel	Palanca del embrague y magneto	
500 Flash ...	1 22 42-8785*	Front Brake Cable	Cable de commande du frein avant	Vorderradbrenskabel	Cable Bowden para freno delantera	
A7,S/S, Royal Tourist, A10S/R, Spitfire Scrambler	1 22 42-8786*	Front Brake Cable	Cable de commande du frein avant	Vorderradbrenskabel	Cable Bowden para freno delantera	
A7 ...	1 22 42-8793	Front Brake Cable	Cable de commande du frein avant	Vorderradbrenskabel	Cable Bowden para freno delantera	
A Group ...	1 23 42-8797**	Clutch Cable	Cable de commande de l'embrayage	Kupplungskabel	Cable Bowden para embrague	
A7 ...	1 22 42-8801**	Front Brake Cable	Cable de commande du frein avant	Vorderradbrenskabel	Cable Bowden para freno delantera	
A7S/S, A10, A10S/R ...	1 22 42-8802**	Front Brake Cable	Cable de commande du frein avant	Vorderradbrenskabel	Cable Bowden para freno delantera	
A7S/S, A10S/R ...	1 31 42-8804**	Ignition Cable	Cable d'allumage	Zündkabel	Ignieion cable	
Spitfire Scrambler, A10S/R	1 37 42-8809	Throttle Twist Grip	Poignée tournante de commande des gaz.	Gasdrehgriff	Puño girante de acelerador	
Spitfire Scrambler, A10S/R	1 13 42-8812	Rubber Grip (left-hand)	Poignée en caoutchouc (gauche)	Gummigriff (links)	Puño fijo de goma (izq.)	
A Group ...	1 14 42-9058	Bracket	Support	Verstrebung	Soporte	
A Group ...	1 07 42-9060	Locking Pin	Goujon de verrouillage	Sperrbolzen	Esparago	2
A Group ...	1 09 42-9077	Stud	Goujon	Stehbolzen	Esparago	2
A Group ...	1 06 42-9183	Rubber Buffer	Butée	Gummipuffer	Tope de goma	
Spitfire Scrambler ...	5 74 42-9210	Dual Seat	Selle double	Doppelsitz	Asiento doble	
A Group ...	5 65 42-9230	Dual Seat	Selle double	Doppelsitz	Asiento doble	
A Group ...	1 46 65-4960	Handlebar	Guidon	Lenker	Manillar	
A Group ...	1 03 65-5446	Bolt	Boulon	Schraube	Tornillo	
A10S/R ...	4 35 65-8501	Throttle Twist Grip	Poignée tournante de commande des gaz.	Gasdrehgriff	Puño girante de acelerador	
A Group ...	1 13 65-8502	Rubber Grip (left-hand)	Poignée en caoutchouc (gauche)	Gummigriff (links)	Puño fijo de goma (izq.)	
A7, A7S/S, A10 ...	1 37 65-8516	Throttle Twist Grip	Poignée tournante de commande	Gasdrehgriff	Puño girante de acelerador	
A7S/S, A10/R ...	1 31 65-8714	Ignition Cable	Cable d'allumage	Zündkabel	Ignieion cable	
A10S/R ...	1 18 67-8527††	Throttle Cable	Comande des gaz	Gaszug	Cable Bowden para acelerador	
A7, A7S/S ...	1 18 67-8530	Throttle Cable	Comande des gaz	Gaszug	Cable Bowden para acelerador	
A10, A10S/R ...	1 18 67-8531*†	Throttle Cable	Comande des gaz	Gaszug	Cable Bowden para acelerador	

*American type.

†For T.T. Carburetter and Standard Handlebar.

**For Western Handlebar.

††For T.T. Carburetter and Western Handlebar.

*†For Monobloc Carburetter.

*Type American.

†Pour carburateur T.T. et guidon normal.

**Pour guidon type American.

††Pour carburateur T.T. et guidon type American.

*†Pour carburateur monbloc.

*Amerikanische Typen.

†für T.T. Vergaser und normalen Lenker.

**für Lenker der Amerikanische Typen.

††für Vergaser und Lenker der Amerikanische Typen.

*†für Monobloc Vergaser.

*Tipo Americano.

†Para carburador T.T. y manillar normal.

**Para manillar tipo Americano.

††Para carburador T.T. y manillar tipo Americano.

*†Para carburador monbloc.

CLASSIC
BIKE SPARES

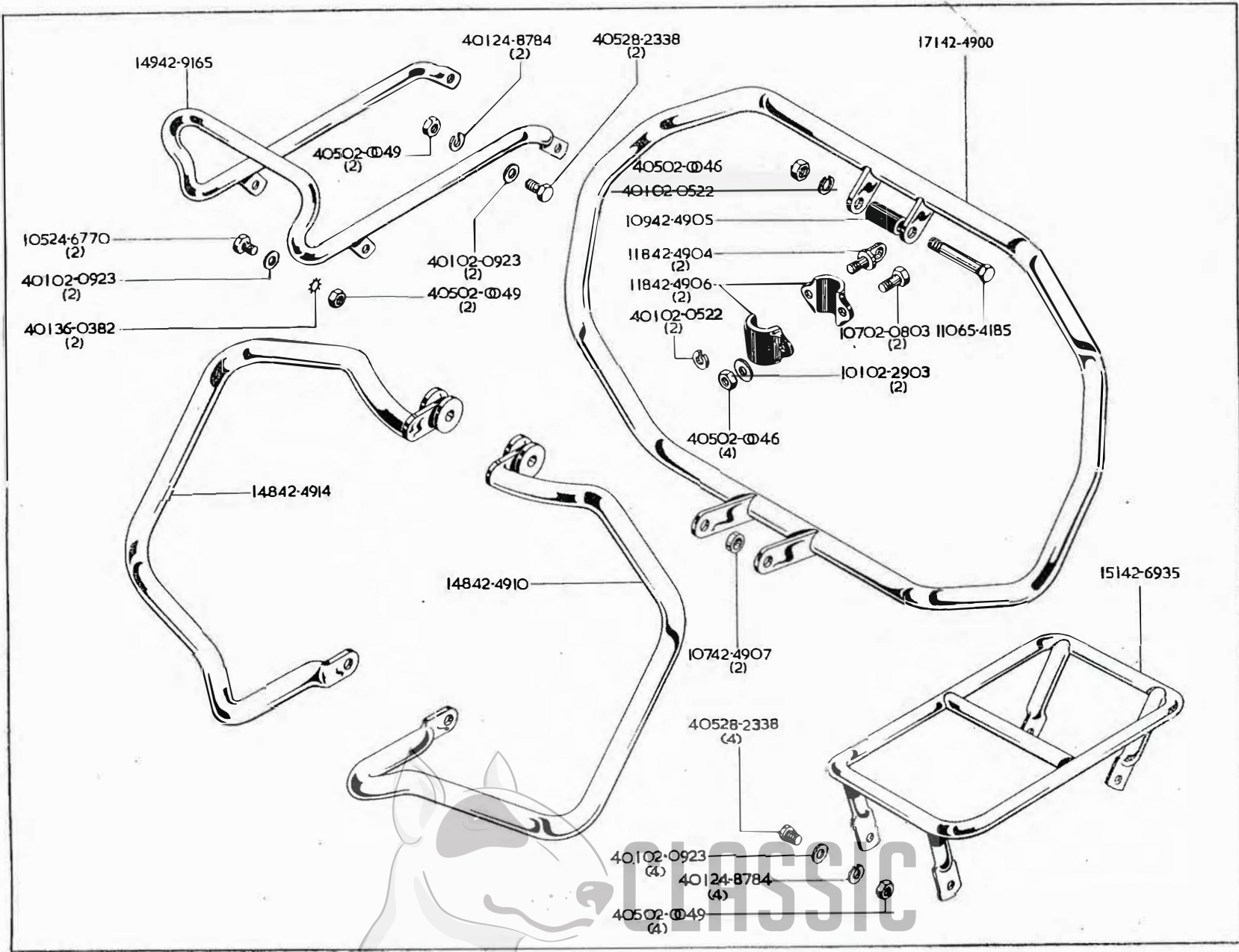

CLASSIC
 BIKE SPARES

**HANDRAIL
POIGNÉE
HALTERING
PUNO**

**CARRIER
PORTE-BAGAGES
GETPÄCKTRÄGER
PORTA-EQUIPAGE**

**SAFETY BARS
PARE-CHOCS
STURZBÜGEL
BARAS DE SEGURIDAD**

Model Modèle Typen Modelos	Spares No. No. de pièce Ersatzteil-Nr. No. de repuesto	Description	Designation	Beschreibung	Descripción	Per Set Par jeu Pr. Satz Juego de
A Group	... 4 05 02-0046	Nut	Écrou	Mutter	Tuerca	9
A Group	... 4 05 02-0049	Nut	Écrou	Mutter	Tuerca	8
A Group	... 4 01 02-0522	Lockwasher	Rondelle frein	Sicherungsscheibe	Freno	8
A Group	... 1 07 02-0803	Bolt	Boulon	Schraube	Tornillo	6
A Group	... 4 01 02-0923	Washer	Rondelle	Scheibe	Arandela	2
A Group	... 1 01 02-2903	Lockwasher	Rondelle frein	Sicherungsscheibe	Freno	2
A Group	... 1 05 24-6770	Bolt	Boulon	Schraube	Tornillo	2
A Group	... 4 01 24-8784	Lockwasher	Rondelle frein	Sicherungsscheibe	Freno	6
A Group	... 4 05 28-2338	Bolt	Boulon	Schraube	Tornillo	4
A Group	... 4 01 36-0382	Lockwasher	Rondelle frein	Sicherungsscheibe	Freno	2
A Group	... 1 71 42-4900	Front Safety Bar	Parachoc av	Vorderer Stürzbogen	Defensa delantera	
A Group	... 1 18 42-4904	Eye Bolt	Boulon à oeil	Ösenbolzen	Tornillo de ojo	
A Group	... 1 09 42-4905	Spacer Bush	Bague entretoise	Distanzbüchse	Anillo espaciador	
A Group	... 1 18 42-4906	Clip complete	Bride complet	Klammer kompl.	Grapa completa	2
A Group	... 1 07 42-4907	Spacer Bush	Bague entretoise	Distanzbüchse	Anillo espaciador	
A Group	... 1 48 42-4910	Safety Bar (right-hand)	Parachoc (droite)	Stürzbogen (rechts)	Defensa (der.)	
A Group	... 1 48 42-4914	Safety Bar (left-hand)	Parachoc (gauche)	Stürzbogen (links)	Defensa (izq.)	
A Group	... 1 51 42-6935	Carrier	Porte-bagages	Gepäckträger	Porte-equipaje	
A Group	... 1 49 42-9165	Handrail	Poignée	Haltering	Puño	
A Group	... 1 10 65-4185	Bolt	Boulon	Schraube	Tornillo	



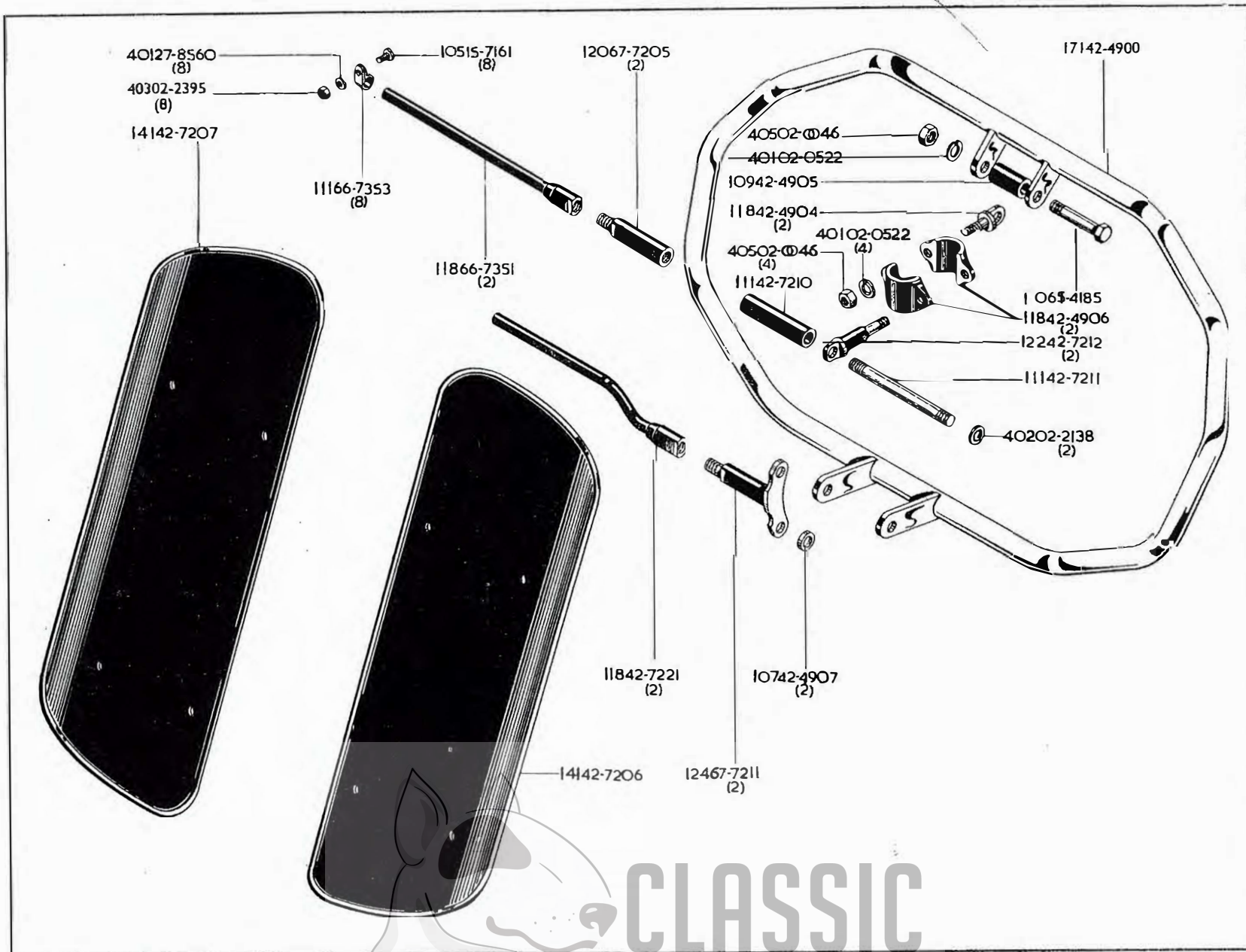

CLASSIC
BIKE SPARES

**LEGSHIELD
PROTÈGE-JAMBES
BEINSCHUTZ
GUARDAPIERNAS**

**SAFETY BARS
PARE-CHOCS
STURZBÜGEL
BARAS DE SEGURIDAD**

Model Modèle Typen Modelos	Spares No. No. de pièce Ersatzteil-Nr. No. de repuesto	Description	Designation	Beschreibung	Descripción	Per Set Par jeu Pr. Satz Juego de
A Group	... 4 05 02-0046	Nut	Écrou	Mutter	Tuerca	5
A Group	... 4 01 02-0522	Lockwasher	Rondelle frein	Sicherungsscheibe	Freno	5
A Group	... 4 02 02-2138	Washer	Rondelle	Scheibe	Arandela	2
A Group	... 4 03 02-2395	Nut	Écrou	Mutter	Tuerca	8
A Group	... 1 05 15-7161	Screw	Vis	Schraube	Tornillo	8
A Group	... 4 01 27-8560	Washer	Rondelle	Scheibe	Arandela	8
A Group	... 1 71 42-4900	Safety Bars	Pare-chocs	Sturzbügel	Baras de seguridad	
A Group	... 1 18 42-4904	Eye Bolt	Boulon à oeil	Ösenbolzen	Tornillo de ojo	2
A Group	... 1 09 42-4905	Distance Piece	Entretoise	Distanzrohr	Distanciador	
A Group	... 1 18 42-4906	Clip complete	Bride complet	Klammer kompl.	Grapa completa	2
A Group	... 1 07 42-4907	Distance Piece	Entretoise	Distanzrohr	Distanciador	2
A Group	... 1 41 42-7206	Legshield (right-hand)	Protège-jambes (droite)	Beinschutz (rechts)	Guardapiernas (der.)	
A Group	... 1 41 42-7207	Legshield (left-hand)	Protège-jambes (gauche)	Beinschutz (links)	Guardapiernas (izq.)	
A Group	... 1 11 42-7210	Distance Piece	Entretoise	Distanzrohr	Distanciador	
A Group	... 1 11 42-7211	Stud	Goujon	Stehbolzen	Espago	
A Group	... 1 22 42-7212	Eye Bolt	Boulon à oeil	Ösenbolzen	Tornillo de ojo	
A Group	... 1 18 42-7221	Support (bottom)	Support (inférieur)	Halter (unten)	Soporte (inferior)	2
A Group	... 1 10 65-4185	Bolt	Boulon	Schraube	Tornillo	
A Group	... 1 18 66-7351	Support (top)	Support (supérieur)	Halter (oben)	Soporte (superior)	2
A Group	... 1 11 66-7353	Clip	Bride	Klammer	Grapa	8
A Group	... 1 20 67-7205	Adaptor	Pièce d'ajustement	Anschlussrohr	Tubo de ajuste	2
A Group	... 1 24 67-7211	Adaptor	Pièce d'ajustement	Anschlussrohr	Tubo de ajuste	2

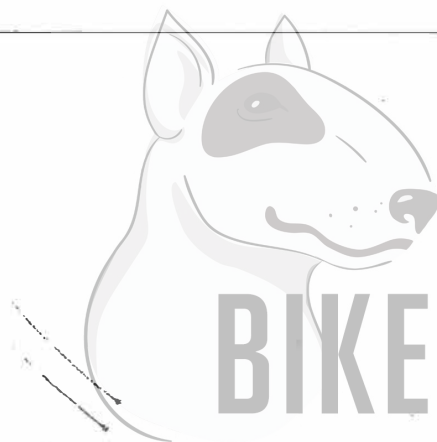

**CLASSIC
BIKE SPARES**

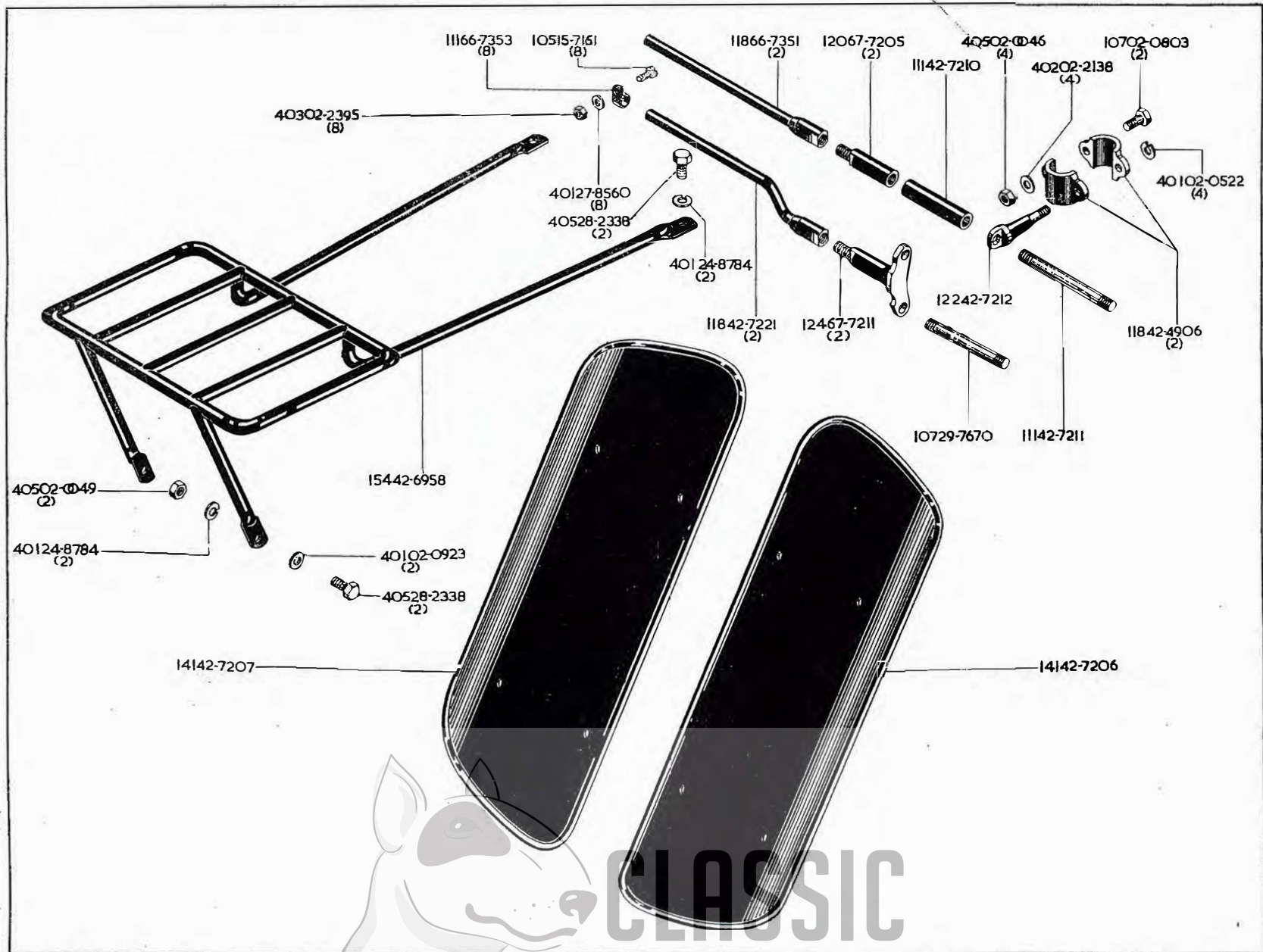

CLASSIC
 BIKE SPARES

**LEGSHEILDS
PROTEGE-JAMBES
BEINSCHUTZ
GUARDAPIERNAS**

**CARRIER
PORTE-BAGAGES
GEPÄCKTRÄGER
PORTA-EQUIPAJE**

Model Modèle Typen Modelos	Spares No. No. de pièce Ersatzteil-Nr. No. de repuesto	Description	Designation	Beschreibung	Descripción	Per Set Par jeu Pr. Satz Juego de
A Group	... 4 05 02-0046	Nut	Écrou	Mutter	Tuerca	4
A Group	... 4 05 02-0049	Nut	Écrou	Mutter	Tuerca	2
A Group	... 4 01 02-0522	Lockwasher	Rondelle frein	Sicherungsscheibe	Freno	4
A Group	... 1 07 02-0803	Bolt	Boulon	Schraube	Tornillo	2
A Group	... 4 01 02-0923	Washer	Rondelle	Scheibe	Arandela	2
A Group	... 4 02 02-2138	Washer	Rondelle	Scheibe	Arandela	4
A Group	... 4 03 02-2395	Nut	Écrou	Mutter	Tuerca	8
A Group	... 1 05 15-7161	Screw	Vis	Schraube	Tornillo	8
A Group	... 4 01 24-8784	Lockwasher	Rondelle frein	Sicherungsscheibe	Freno	4
A Group	... 4 01 27-8560	Washer	Rondelle	Scheibe	Arandela	8
A Group	... 4 05 28-2338	Bolt	Boulon	Schraube	Tornillo	4
A Group	... 1 07 29-7670	Stud	Goujon	Stehbolzen	Esparago	
A Group	... 1 18 42-4906	Clip complete	Bride complet	Klammer kompl.	Grapa completa	2
A Group	... 1 54 42-6958	Carrier	Porte-bagages	Gepäckträger	Porta-equipaje	
A Group	... 1 41 42-7206	Legshield (right-hand)	Protège-jambes (droite)	Beinschutz (rechts)	Guardapiernas (der.)	
A Group	... 1 41 42-7207	Legshield (left-hand)	Protège-jambes (gauche)	Beinschutz (links)	Guardapiernas (izq.)	
A Group	... 1 11 42-7210	Distance Piece	Entretoise	Distanzrohr	Distanciador	
A Group	... 1 11 42-7211	Stud	Goujon	Stehbolzen	Esparago	
A Group	... 1 22 42-7212	Eye Bolt	Boulon à oeil	Ösenbolzen	Tornillo de ojo	
A Group	... 1 18 42-7221	Support (bottom)	Support (inférieur)	Halter (unten)	Soporte (inferior)	2
A Group	... 1 18 66-7351	Support (top)	Support (supérieur)	Halter (oben)	Soporte (superior)	2
A Group	... 1 11 66-7353	Clip	Bride	Klammer	Grapa	
A Group	... 1 20 67-7205	Adaptor (top)	Pièce d'ajustement (supérieur)	Anschlussrohr (oben)	Tubo de ajuste (superior)	2
A Group	... 1 24 67-7211	Adaptor	Pièce d'ajustement	Anschlussrohr	Tubo de ajuste	2

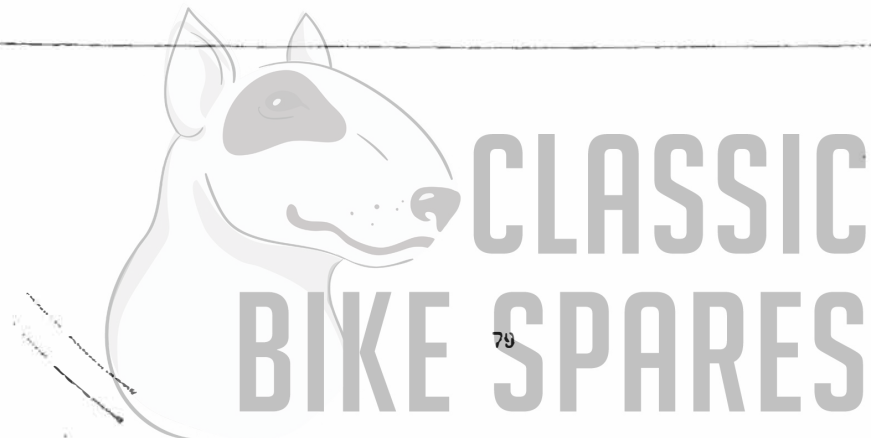

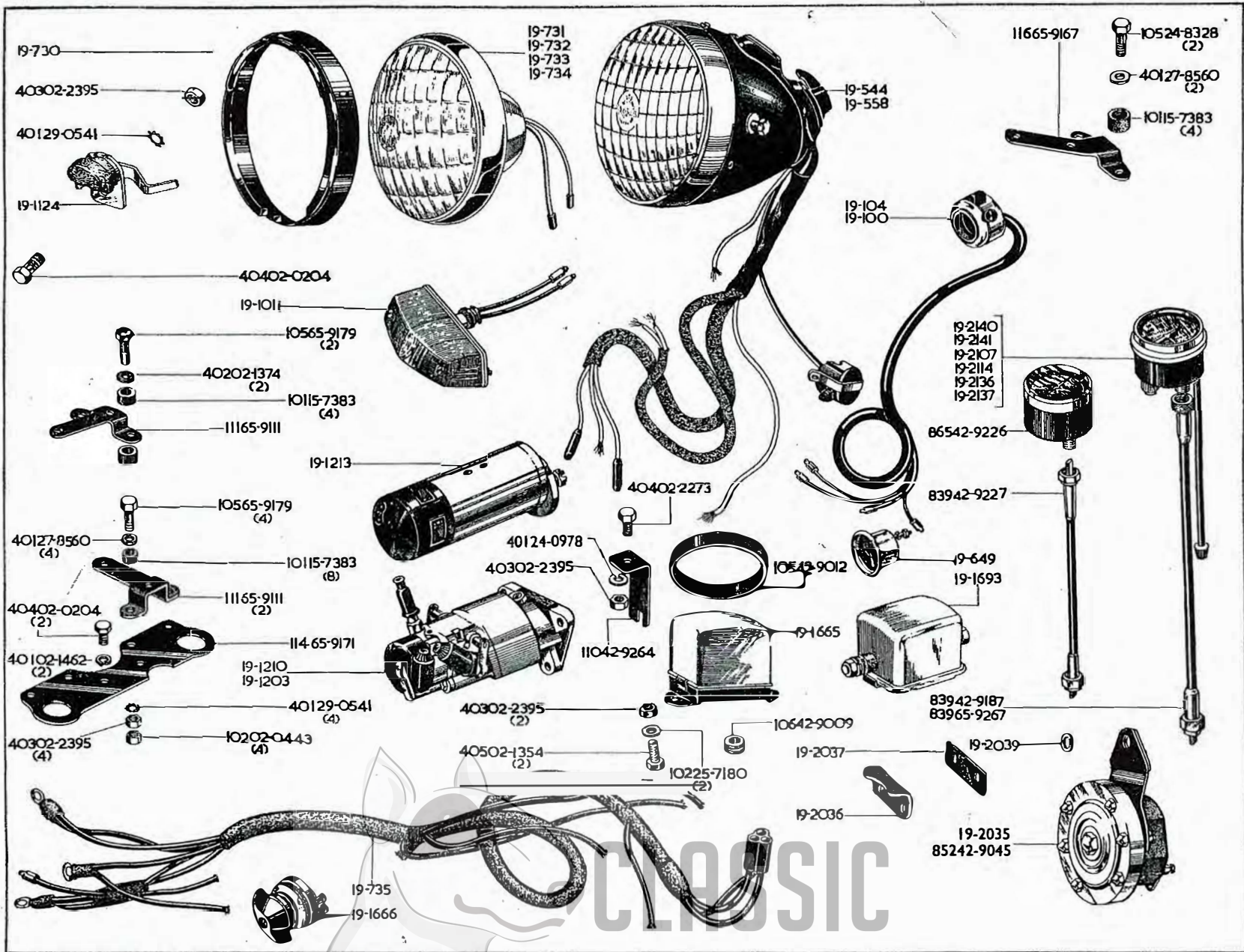

CLASSIC
 BIKE SPARES

**EQUIPMENT
EQUIPEMENT
AUSRÜSTUNG
EQUIPO**

Model Modèle Typen Modelos	Spare No. No. de pièce Ersatzteil-Nr. No. de repuesto	Description	Designation	Beschreibung	Descripción	Makers No. No. du fabricant Nr.-Hersteller No. fabricante
A10S/R ...	4 04 02-0204	Bolt	Boulon	Schraube	Tornillo	
A10S/R ...	1 02 02-0443	Nut	Ecrou	Mutter	Tuerca	
A Group ...	4 05 02-1354	Bolt	Boulon	Schraube	Tornillo	
A10S/R ...	4 02 02-1374*	Washer	Rondelle	Scheibe	Arandela	
A10S/R ...	4 01 02-1462	Lockwasher	Rondelle frein	Sicherungsscheibe	Freno	
A Group ...	4 04 02-2273	Bolt	Boulon	Schraube	Tornillo	
A Group ...	4 03 02-2395	Nut	Ecrou	Mutter	Tuerca	
A10S/R ...	4 03 02-2395	Nut	Ecrou	Mutter	Tuerca	
A10S/R ...	1 01 15-7383	Rubber Sleeve	Douille, caoutchouc	Gummimuffe	Manguita de goma	
A Group ...	19-0100	Horn and Dipswitch	Avertisseur et inverseur code-phare.	Hupe und Abblendschalter	Bocina y conmutador de cruce.	09103
A10S/R ...	19-0104*	Horn and Dipswitch	Avertisseur et inverseur code-phare.	Hupe und Abblendschalter	Bocina y conmutador de cruce.	09104
A10S/R ...	19-0544	Headlamp	Phare complet	Scheinwerfer kompl.	Faro completa	057421
A10S/R ...	19-0558	Headlamp (American type)	Phare complet (type American)	Scheinwerfer kompl. (Amerikanische Typen).	Faro completa (tipo Americano).	057547
A Group ...	19-0649	Ammeter	Ampèremètre	Amperemeter	Amperimetro	36084
A Group ...	19-0730	Headlamp Support Ring	Portière de phare	Haltering für Scheinwerfer	Anillo des oporte del faro	556402
A Group ...	19-0731	Headlamp Unit	Phare complet	Scheinwerfer kompl.	Faro completa	58158
A7, A7S/S, A10	19-0732	Light Unit (Export)	Phare complet (Export)	Scheinwerfer kompl. (Ausfuhr)	Faro completa (Exportación)	516810
A7, A7S/S, A10	19-0733	Light Unit (Continental)	Phare complet (Continental)	Scheinwerfer kompl. (Kontinental).	Faro completa (Continental)	516811
A7, A7S/S, A10	19-0734	Light Unit (French)	Phare complet (Francias)	Scheinwerfer kompl. (Französisch).	Faro completa (Frances)	516802
A Group ...	19-0735	Harness complete	Faisceau de câbles complet	Kabelstrang kompl	Juego de cables completa	839780
A Group ...	19-1011	Rear Lamp	Feu rouge arrière	Schlusslicht	Luz roja trasera	53432
A Group ...	19-1124	Stop Lamp Switch	Commutateur de lampe de stop	Stoplichtschalter	Interruptor para la luz "stop"	34257
A7S/S, A10S/R	19-1203	Magneto	Magneto	Magnet	Magneto	42380
A7, A10	19-1210	Magneto	Magneto	Magnet	Magneto	045727
A Group ...	19-1213	Dynamo	Dynamo	Lichtmaschine	Dinamo	20036
A Group ...	19-1552	Battery	Batterie	Batterie	Bateria	4084077
A Group ...	19-1665	Control Box	Boîte de commande	Steuerdose	Caja de control	37225
A Group ...	19-1666	Switch	Interrupteur	Schalter	Interrupter	31763
A Group ...	19-1670**	Battery	Batterie	Batterie	Bateria	54028263

*Less Cowl fitting.	*Sans accessoire pour capot.	*Ohne Haubebeschlag.	*Sin accesorio para capucha.
†With Cowl fitting.	†Avec accessoire pour capot.	†Mit Haubebeschlag.	†Con accesorio para capucha.
**Fitted on and after Frame No.	**Montée depuis cadre numéro	**Nach Rahmennummer montiert	**Montada después de cuadro numero
A7 ... GA7-8855	A7 ... GA7-8855	A7 ... GA7-8855	A7 ... GA7-8855
A7S/S ... GA7-8929	A7S/S ... GA7-8929	A7S/S ... GA7-8929	A7S/S ... GA7-8929
A10 ... GA7-8437	A10 ... GA7-8437	A10 ... GA7-8437	A10 ... GA7-8437
A10S/R ... GA7-8618	A10S/R ... GA7-8618	A10S/R ... GA7-8618	A10S/R ... GA7-8618
*†Fitted on and after Frame No.	*†Montée depuis cadre numéro	*†Nach Rahmennummer montiert.	*†Montada después cuadro numero
A7, A7S/S... GA7-8124	A7, A7S/S... GA7-8124	A7, A7S/S... GA7-8124	A7, A7S/S... GA7-8124
A10 ... GA7-8324	A10 ... GA7-8324	A10 ... GA7-8324	A10R... GA7-8324
A10S/R ... GA7-8319	A10S/R ... GA7-8319	A10S/R ... GA7-8319	A10S/RS ... GA7-8319

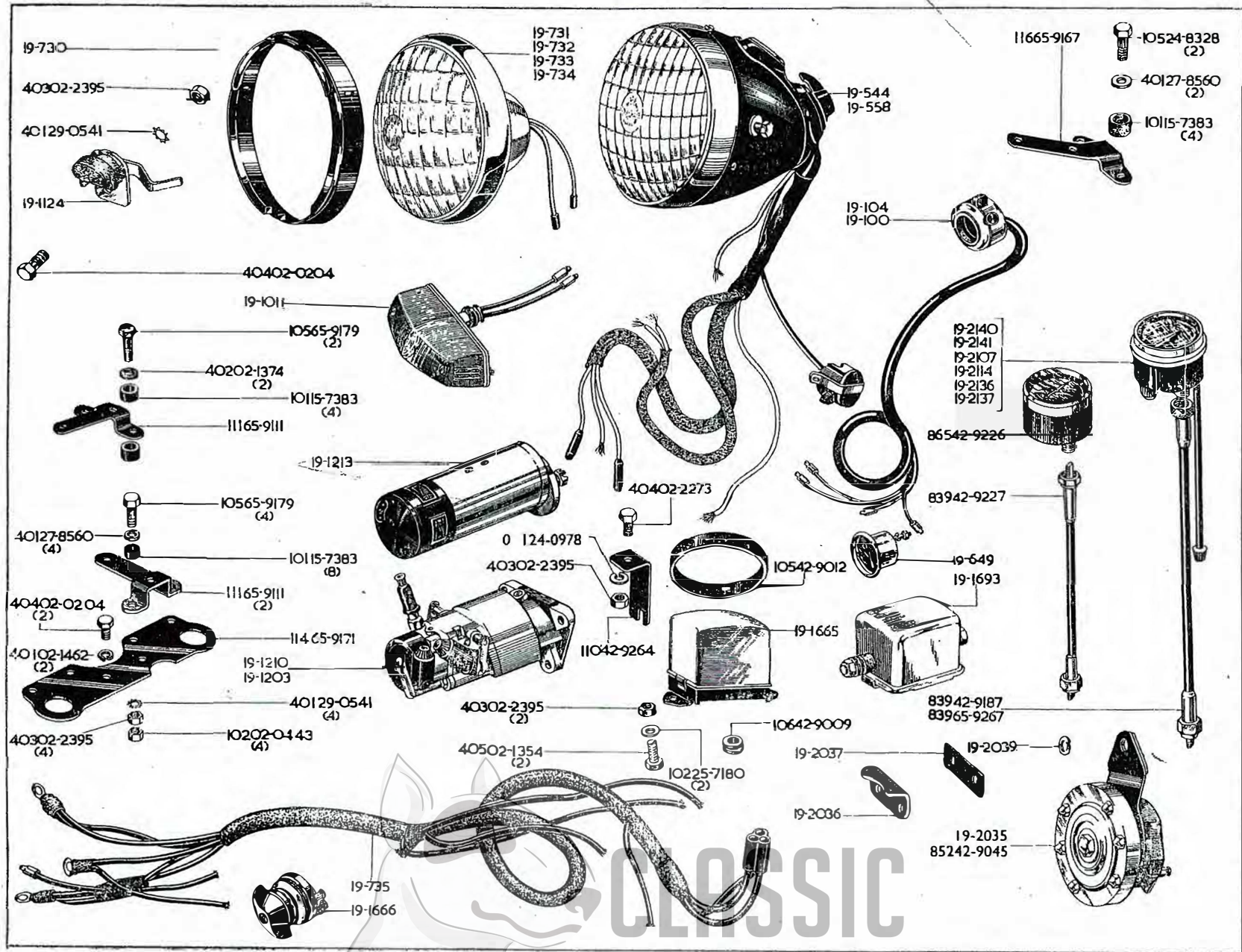

CLASSIC BIKE SPARES

**EQUIPMENT
EQUIPMENT
AUSRUSTUNG
EQUIPO**

Model Modèle Typen Modelos	Spares No. No. de pièce Ersatzteil-Nr. No. de repuesto	Description	Designation	Beschreibung	Descripción	Per Set Par jeu Pr. Satz Juego de
A Group	19-1693*†	Control Box	Boîte de commande	Steuerdose	Caja de control	37221
A Group	19-2035†	Horn	Avertisseur	Hupe	Bocina	70137
A Group	19-2036	Bracket	Support	Verstrebung	Soporte	701879
A Group	19-2037	Distance Piece	Entretoise	Distanzrohr	Distanciador	700778
A Group	19-2038	Bolt	Boulon	Schraube	Tornillo	127705
A Group	19-2039	Washer	Rondelle	Scheibe	Arandela	183030
A1 0S/R	19-2107*	Speedo Head (m.p.h.)	Compteur de vitesses (m.p.h.)	Tachometer (m.p.h.)	Velocimetro (m.p.h.)	S546/3/L
A10S/R	19-2114*	Speedo Head (k.p.h.)	Compteur de vitesses (k.p.h.)	Tachometer (k.p.h.)	Velocimetro (k.p.h.)	S546/7/L
A7, A7S/S Solo, A10 Solo & S/car, A10S/R	19-2136†	Speedo Head (m.p.h.)	Compteur de vitesses (m.p.h.)	Tachometer (m.p.h.)	Velocimetro (m.p.h.)	SC3305/04
A7, A7S/S Solo, A10 Solo & S/car, A10S/R	19-2137†	Speedo Head (k.p.h.)	Compteur de vitesses (k.p.h.)	Tachometer (k.p.h.)	Velocimetro (k.p.h.)	SC3305/05
A7, A7S/S S/car ...	19-2140	Speedo Head (m.p.h.)	Compteur de vitesses (m.p.h.)	Tachometer (m.p.h.)	Velocimetro (m.p.h.)	SC3305/06
A7, A7S/S S/car ...	19-2141	Speedo Head (k.p.h.)	Compteur de vitesses (k.p.h.)	Tachometer (k.p.h.)	Velocimetro (k.p.h.)	SC3305/07
A Group	4 01 24-0978	Lockwasher	Rondelle frein	Sicherungsscheibe	Freno	
A10S/R	1 05 24-8328	Bolt	Boulon	Schraube	Tornillo	
A Group	1 02 25-7180	Washer	Rondelle	Scheibe	Arandela	
A10S/R	4 01 27-8560	Washer	Rondelle	Scheibe	Arandela	
A10S/R	4 01 29-0541	Lockwasher	Rondelle frein	Sicherungsscheibe	Freno	
A Group	1 06 42-9009	Grommet	Rondelle capuchon	Tülle	Manguera	
A Group	1 05 42-9012	Rubber Ring	Bague, caoutchouc	Gummiring	Anillo de goma	
A10S/R	8 52 42-9045*	Horn	Avertisseur	Hupe	Bocina	069482
A Group	8 39 42-9187	Speedo Cable	Câble de compteur	Tachometerkabel	Arbol de transmisión del velocimetro.	DF1110/20
A10S/R	8 65 42-9226	Rev. Counter	Compte-tours	Drehzahlmesser	Contador de vueltas	RC1303/03
A10S/R	8 39 42-9227	Rev. Counter Cable	Câble de compteur	Tachometerkabel	Arbol de transmisión del velocimetro.	DF1110/20
A Group	1 10 42-9264	Bracket	Support	Verstrebung	Soporte	
A10S/R	1 11 65-9111	Bracket	Support	Verstrebung	Soporte	
A10S/R	1 16 65-9167	Bracket	Support	Verstrebung	Soporte	
A10S/R	1 14 65-9171	Plate	Plaque	Scheibe	Placa	
A10S/R	1 05 65-9179*	Bolt	Boulon	Schraube	Tornillo	
A10S/R	8 39 65-9267*	Speedo Cable	Câble de compteur	Tachometerkabel	Arbol de transmisión del velocimetro.	DF1110/20

*Less Cowl fitting.

†With* Cowl fitting.

*Fitted on and after
Frame No.

A7 ... GA7-8855
A7S/S ... GA7-8929
A10 ... GA7-8437
A10S/R ... GA7-8618

*†Fitted on and after
Frame No.

A7, A7S/S... GA7-8124
A10 ... GA7-8324
A10S/R ... GA7-8319

*Sans accessoire pour capot.

†Avec accessoire pour capot.

**Montée depuis cadre numéro

A7 ... GA7-8855
A7S/S ... GA7-8929
A10 ... GA7-8437
A10S/R ... GA7-8618

*†Montée depuis cadre numéro

A7, A7S/S... GA7-8124
A10 ... GA7-8324
A10S/R ... GA7-8319

*Ohne Haubebeschlag.

†Mit Haubebschlag.

**Nach Rahmennummer
montiert

A7 ... GA7-8855
A7S/S ... GA7-8929
A10 ... GA7-8437
A10S/R ... GA7-8616

*†Nach Rahmennummer
montiert.

A7, A7S/S... GA7-8124
A10 ... GA7-8324
A10S/R ... GA7-8319

*Sin accesorio para capucha.

†Con accesorio para capucha.

**Montada después de cuadro numero

A7 ... GA7-8855
A7S/S ... GA7-8929
A10 ... GA7-8437
A10S/R ... GA7-8618

*†Montada después cuadro numero

A7, A7S/S... GA7-8124
A10 ... GA7-8324
A10S/R ... GA7-8319

11265-9246



52290-9237

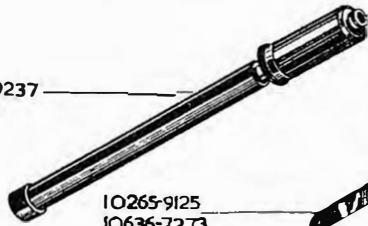

10265-9125
10636-7273



19-1600



11065-9282

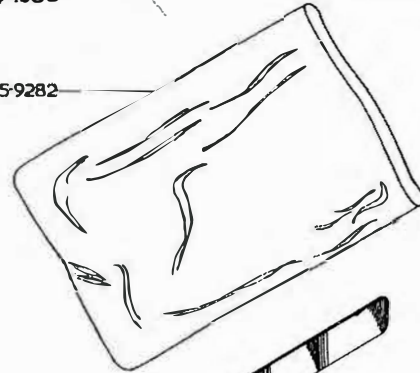

12167-9026



12267-9028



11267-9114

51642-9273

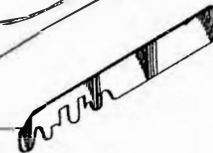

11129-9252



40266-9049
(15)



11242-9080

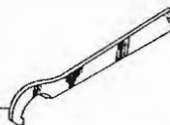

81167-9122



41467-9023



11465-9243



91476-9206



10729-9253



11867-9121



11229-9257
10966-9036



11465-9205

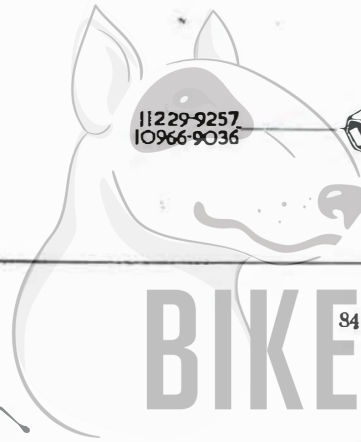

CLASSIC BIKE SPARES

**TOOLS
OUTILS
WERKZEUGE
HERRAMIENTOS**

**SUNDRIES
PIECES DIVERSUS
SONSTIGE TEILE
PIEZAS VARIAS**

Model Modèle Typen Modelos	Spare No. No. de pièce Ersatzteil-Nr. No. de repuesto	Description	Designation	Beschreibung	Descripción	Per Set Par jeu Pr. Satz Juego de
A Group	19-1600	Grommet	Rondelle capuchon	Tülle	Manguera	
A Group	1 11 29-9252	Tyre Lever	Démonte-pneu	Reifenheber	Palanca desmonta-neumaticos	
A Group	1 07 29-9253	Tommy Bar	Broche	Montiereisen	Barra para llaves de tubo	
A Group	1 12 29-9257	Box Spanner	Clé à tube	Steckschlüssel	Llave de freno	
A Group	1 06 36-7273	Feeler Gauge (.008 in.)	Calibre à lames (.203 mm.)	Spion (.203 mm.)	Calibrador de cinta (.203 mm.)	
A Group	1 12 42-9080	Single Ended Spanner	Clé à une fourche	Schraubenschlüssel	Llave de una boca	
A Group	1 47 42-9184	Tool Kit complete	Outilsage complet	Werkzeug kompl.	Herramientos completa	
A Group	5 16 42-9273	Licence Holder	Porte-permis	Lizenzhalter	Portalicencia	
A Group	1 02 65-9125	Feeler Gauge (.010 in.)	Calibre à lames (.254 mm.)	Spion (.254 mm.)	Calibrador de cinta (.254 mm.)	
A Group	1 14 65-9243	Double Ended Spanner	Clé à fourche double	Doppelschraubenschlüssel	Llave de dos bocas	
A Group	1 12 65-9246	Double Ended Spanner	Clé à fourche double	Doppelschraubenschlüssel	Llave de dos bocas	
A Group	1 14 65-9266	Box Spanner	Clé à tube	Steckschlüssel	Llave de tubo	
A Group	1 10 65-9282	Tool Bag	Trousse à outils	Werkzeughülle	Bolsa de herramientas	
A Group	1 09 66-9036	Box Spanner	Clé à tube	Steckschlüssel	Llave de tubo	
A Group	4 02 66-9049	Cable Clip	Attache pour câble	Kabelklemme	Abrazadera de cable	15
A Group	4 14 67-9023	Box Spanner	Clé à tube	Steckschlüssel	Llave de tubo	
A Group	1 21 67-9026	Ring Spanner	Clé annulaire	Ringschlüssel	Llave anular	
A Group	1 22 67-9028	Double Ended Spanner	Clé à fourche double	Doppelschraubenschlüssel	Llave de dos bocas	
A Group	1 12 67-9114	Push Rod Assembly Tool	Outil pour montage des poussoirs.	Werkzeug zum montieren der Stößel.	Herramienta para el montaje de las levantavalvulas.	
A Group	1 18 67-9121	Box Spanner	Clé à tube	Steckschlüssel	Llave de tubo	
A Group	8 11 67-9122	Magdyno Spanner	Clé pour magdyno	Schlüssel Für Magdyno	Llave para magdyno	
A Group	9 14 76-9206	Double Ended Spanner	Clé à fourche-double	Doppelschraubenschlüssel	Llave de dos bocas	
A Group	5 22 90-9273	Inflator	Pompe à air	Luftpumpe	Bomba de aire	



**SUPPLEMENT OF SPARE PARTS
FOR A7, A10 POLICE RADIO MODELS**

**LISTE SUPPLEMENTAIRE DE PIÈCES
DÉTACHÉS POUR A7, A10
POLICE RADIO MODÈLE**

**ERGÄNZUNG FÜR A7, A10
POLIZEI RADIO TYPEN
ERSATZTEILE**

**LISTA ADICIONAL DE PIEZAS
DE RECAMBIO PARA LA A7, A10
POLICÍA RADIO MODELOS**



ENGINE
MOTEUR
MOTOR

Model Modèle Typen Modelos	Spares No. No. de pièce Ersatzteil-nr No. de repuesto	Description	Designation	Beschreibung	Descripción	Fer Set Par jeu Pr Satz Juego de
A7 ...	1 84 42-0081	Crankshaft complete	Vilebrequin complet	Kurbelwelle komplett	Cigüeñal completa	
A7 ...	1 34 42-0087	Engine Sprocket (18T)	Pignon-moteur D 18	Motorritzel Z-18	Piñon de motor D-18	
A10 ...	1 89 42-0091	Crankshaft complete	Vilebrequin complet	Kurbelwelle komplett	Cigüeñal completa	
A7, A10 ...	1 06 67-1213	Flywheel Bolt	Boulon pour volant	Schraube für Schwungmasse	Tornillo para volante	2
A7, A10 ...	1 14 67-1215	Flywheel Bolt (oil tube location).	Boulon pour volant	Schraube für Schwungmasse	Tornillo para volante	
A7, A10 ...	1 11 67-1212	Crankshaft Grub Screw	Vis sans tête	Madenschraube	Tornillo prisionero	
A7, A10 ...	4 01 66-4707	Flywheel Bolt Washer	Rondelle	Scheibe	Arandela	3
A7, A10 ...	1 19 42-0086	Engine Sprocket Distance Piece	Entretoise pour pignon-moteur D-18.	Distanzrohr für Motorritzel Z-18.	Distanciador para piñon de motor D-18.	
A7, A10 ...	19-1222	Alternator	Alternateur	Lichtmaschine	Alternador	
A7, A10 ...	4 05 29-0925	Alternator Key	Clavette pour alternateur	Rundkeil für Lichtmaschine	Chaveta Woodruff para alternador	
A7, A10 ...	1 11 29-2031	Alternator Spinner	Plaque pour alternateur	Platte für Lichtmaschine	Placa para alternador	
A7, A10 ...	1 02 29-2024	Alternator Lockwasher	Rondelle frein	Sicherungsscheibe	Freno	
A7, A10 ...	1 09 29-2023	Alternator Nut	Écrou	Mutter	Tuerca	
A10 ...	1 58 42-2858	Exhaust Pipe (n/s)	Tuyau d'échappement (gauche)	Auspuffrohr (links)	Tubo de escape (izq.)	
A7 ...	1 58 42-2856	Exhaust Pipe (n/s)	Tuyau d'échappement (gauche)	Auspuffrohr (links)	Tubo de escape (izq.)	



CLASSIC
BIKE SPARES

**CLUTCH
EMBRAYAGE
KUPPLUNG
EMBRAGUE**

Model Modèle Typen Modelos	Spares No. No de pièce Ersatzteil-nr No. de repuesto	Description	Designation	Beschreibung	Descripción	Per Set Per jeu Pr Satz Juego de
A7, A10 ...	1 33 42-3184	Clutch Spider	Croisillon de l'embrayage	Kupplungskreuz	Estrella de embrague	
A7, A10 ...	1 09 42-3202	Drive Rubber	Tampon caoutchouc	Gummiauflage	Cojín de goma	4
A7, A10 ...	1 09 42-3201	Rebound Rubber	Butée caoutchouc	Gummipuffer	Tope de goma	4
A7, A10 ...	1 81 42-3168	Clutch complete with Armstrong Segments.	Embrayage complet avec segment - Armstrong.	Kupplung Komplet mit Segment - Armstrong.	Embrague completa con sector - Armstrong.	
A7, A10 ...	1 81 42-3169	Clutch complete with Ferodo Segments.	Embrayage complet avec segment - Ferodo.	Kupplung Komplet mit Segment - Ferodo.	Embrague completa con sector - Ferodo.	
A7, A10 ...	1 51 42-3175	Clutch Chainwheel	Couronne d'embrayage	Kupplungskettenrad	Piñón de cadena del embrague	
A7, A10 ...	1 02 42-3206	Clutch Roller	Rouleau	Rolle	Rodilló	20
A7, A10 ...	1 20 42-3187	Retaining Plate (outer)	Plaque de retient (extérieur)	Haltescheibe (Aussen)	Placa retenedora (exterior)	
A7, A10 ...	1 39 42-3181	Clutch Centre	Moyeux d'embrayage	Kupplungsnahe	Cubo de embrague	
A7, A10 ...	1 29 42-3182	Retaining Plate (inner)	Plaque de retient (intérieur)	Haltescheibe (Innen)	Placa retenedora (interior)	
A7, A10 ...	1 01 42-3183	Inner Retaining Plate Screw	Vis	Schraube	Tornillo	4
A7, A10 ...	1 09 42-3190	Mainshaft Nut Washer	Rondelle pour arbre primaire	Scheibe für Getriebwelle	Arandela para árbol principal	
A7, A10 ...	1 01 42-3191	Mainshaft Nut Tab Washer	Rondelle frein	Sicherungsscheibe	Freno	
A7, A10 ...	1 09 42-3171	Mainshaft Nut	Ecrou pour arbre primaire	Mutter für Getriebwelle	Tuerca para árbol principal	
A7, A10 ...	1 30 42-3192	Driving Plate complete with Armstrong Segments.	Disque d'entraînement avec segment - Armstrong.	Mitnehmerplatte mit Segment - Armstrong.	Placa de manda con sector - Armstrong.	5
A7, A10 ...	1 37 42-3262	Driving Plate complete with Ferodo Segments.	Disque d'entraînement avec segment - Ferodo.	Mitnehmerplatte mit Segment - Ferodo.	Placa de manda con sector - Ferodo.	5
A7, A10 ...	1 17 42-9177	Clutch Key	Clé pour d'embrayage	Schlüssel für Kupplung	Llave para embrague	
A7, A10 ...	8 26 61-1912	Clutch Extractor complete	Outil pour enlèvement d'embrayage	Kupplungs - Auszieher	Herramienta para embrague	
A7, A10 ...	1 12 65-3940	Clutch Operating Rod	Tige d'embrayage	Kupplungsdruckstange	Varilla del embrague	



**FRAME
CADRE
RAHMEN
CUADRO**

Model Modèle Typen Modelos	Spare No. No. de pièce Ersatzteil-nr No. de repuesto	Description	Designation	Beschreibung	Descripción	Per Set Par jeu Pr Satz Juego de
A7, A10 ...	1 37 42-4765	Prop Stand	Béquille latérale	Seitenstütze	Muleta - lateral	
A7, A10 ...	1 33 67-4888	Prop Stand (Export)	Béquille latérale (Export)	Seitenstütze (Ausfuhr)	Muleta - lateral (Exportación)	

**PETROL TANK
RESERVOIR D'ESSENCE
BENZINTANK
DEPOSITO DE COMBUSTIBLE**

Model Modèle Typen Modelos	Spare No. No. de pièce Ersatzteil-nr No. de repuesto	Description	Designation	Beschreibung	Descripción	Per Set Par jeu Pr. Satz Juego de
A7, A10 ...	1 83 42-8119	Petrol Tank - B.C.C. Radio	Réservoir d'essence - B.C.C. Radio	Benzintank - B.C.C. Radio	Deposito de combustible - B.C.C. Radio.	
A7, A10 ...	1 05 24-8328	Petrol Tank and Control Box Screw.	Vis pour réservoir d'essence	Schraube für Benzintank	Tornillo - deposito de combustible.	4
A7, A10 ...	4 01 27-8560	Petrol Tank and Control Box Washer.	Rondelle pour réservoir d'essence	Scheibe für Benzintank	Scheibe - deposito de combustible.	4
A7, A10 ...	42-8123	Petrol Tank - Cossor Radio	Réservoir d'essence - Cossor Radio.	Benzintank - Cossor Radio	Deposito de combustible - Cossor Radio.	
A7, A10 ...	1 21 42-8124	Petrol Tank Mounting Rubber	Tampon caoutchouc - réservoir d'essence.	Gummiauflage - Benzintank	Cojín de goma - deposito de combustible.	
A7, A10 ...	1 12 42-8126	Petrol Tank Fixing Bolt (centre)	Boulon - réservoir d'essence	Schraube - Benzintank	Tornillo - deposito de combustible	
A7, A10 ...	1 09 42-8127	Petrol Tank Mounting Rubber	Tampon caoutchouc - réservoir d'essence.	Gummiauflage - Benzintank	Cojín de goma - deposito de combustible.	



**CLASSIC
BIKE SPARES**

PRIMARY COVER
COUVERCLE PRIMAIRE
PRIMARKAPPE
TAPA PRIMARIO

Model Modèle Typen Modelos	Spares No. No. de pièce Ersatzteil-nr No. de repuesto	Description	Designation	Beschreibung	Descripción	Per Set Par jeu Pr. Satz Juego de
A7, A10 ...	1 56 42-7529	Primary Chaincase (front)	Couvercle primaire (avant)	Primarkappe (Vordere)	Tapa Primario (delantera)	
A7, A10 ...	1 53 42-7528	Primary Chaincase (back)	Couvercle primaire (arrière)	Primarkappe (Hintere)	Tapa primario (trasera)	
A7, A10 ...	1 07 42-7530	Primary Chaincase Joint Washer	Joint pour couvercle primaire	Dichtung für Primarkappe	Empaquetadura	
A7, A10 ...	1 16 42-7535	Chaincase and Crankcase Flange Washer.	Joint	Dichtung	Empaquetadura	
A7, A10 ...	1 43 42-7531	Chaincase Inspection Cover	Couvercle d'inspection	Inspektionkappe	Tapa	
A7, A10 ...	1 01 42-7532	Chaincase Inspection Cover Washer.	Rondelle pour couvercle d'inspection.	Scheibe für Inspektionkappe	Arandela para tapa	
A7, A10 ...	4 02 42-7539	Chaincase Cable Grommet (back)	Rondele capuchon	Tülle	Manguera	
A7, A10 ...	1 05 65-2158	Inspection Cover to Chaincase Screw.	Vis	Schraube	Tornillo	3
A7, A10 ...	4 01 29-0541	Inspection Cover Washer	Rondelle frein	Sicherungsscheibe	Freno	3
A7, A10 ...	1 07 42-7536	Chaincase to Crankcase Bolt	Boulon	Schraube	Tornillo	2
A7, A10 ...	1 07 42-7533	Chaincase Front Fixing Screw	Vis	Schraube	Tornillo	2
A7, A10 ...	1 05 42-7534	Chaincase Front Fixing Screw	Vis	Schraube	Tornillo	
A7, A10 ...	1 03 67-1395	Alternator Stator Fixing Stud	Goujon	Stehbolzen	Esparago	3
A7, A10 ...	1 06 42-7540	Alternator Distance Piece	Entretoise	Distanzrohr	Distanciador	3
A7, A10 ...	1 06 42-3249	Alternator Fixing Stud Nut	Ecrou	Mutter	Tuerca	3

BATTERY HOLDER
SUPPORT DE BATTERIE
BATTERIEHALTER
PORTA-BATERIA

Model Modèle Typen Modelos	Spares No. No. de pièce Ersatzteil-nr No. de repuesto	Description	Designation	Beschreibung	Descripción	Per Set Par jeu Pr. Satz Juego de
A7, A10 ...	1 47 42-4638	Battery Carrier complete	Support de batterie complet	Batteriehalter Komplett	Porta-bateria completa	
A7, A10 ...	1 37 42-4639	Battery Base Plate	Embase	Unterlage	Placa de base	
A7, A10 ...	1 18 42-4516	Battery Strap (side)	Barrette de batterie (côte)	Batteriehalter (Hülse)	Porta-bateria (lado)	
A7, A10 ...	1 09 66-4603	Battery Strap Bolt	Boulon - barrette de batterie	Schraube für Batteriehalter	Tornillo - porta bateria	2
A7, A10 ...	1 21 42-4541	Battery Strap (top)	Barrette de batterie (dessus)	Batteriehalter (Oben)	Porta-bateria (superior)	
A7, A10 ...	1 12 42-4543	Battery Support Rubber	Recouvrement-caoutchouc pour batterie.	Gummibelag für Batteriehalter.	Estera de goma para bateria	

CLASSIC
BIKE SPARES

**TOOLBOX
BOITE A OUTILS
WERKZEUGKASTEN
CAJA DE HERRAMIENTOS**

**SADDLE
SELLE
SATTEL
SILLIN**

Model Modèle Typen Modelos	Spares No. No. de pièce Ersatzteil-nr No. de repuesto	Description	Designation	Beschreibung	Descripción	Per Set Par jeu Pr. Satz Juego de
A7, A10 5 57 42-9134	Saddle (hinge type)	Selle (type charnière)	Sattel (Scharnier Typen)	Sillín (tipo bisagra)	
A7, A10 4 01 02-0923	Saddle Fixing Stud Washer	Rondelle pour goujon	Scheibe für Stehbolzen	Arandela para esparago	
A7, A10 4 05 02-0049	Saddle Fixing Stud Nut	Ecrou pour goujou	Mutter für Stehbolzen	Tuerca para esparago	
A7, A10 1 63 42-9276	Toolbox	Boîte à outils	Werkzeugkasten	Caja de herramientas	

**EQUIPMENT
EQUIPEMENT
AUSRÜSTUNG
EQUIPO**

Model Modèle Typen Modelos	Spares No. No. de pièce Ersatzteil-nr No. de repuesto	Description	Designation	Beschreibung	Descripción	Makers No. No. du fabricant Nr.-Hersteller No. fabricante
A7, A10 —	Main Wiring Harness	Faisceau de câbles complet	Kabelstrang Komplet	Juego de cables completa	Lucas 54033126
A7, A10†	... —	Speedometer (k.p.h.)	Indicateur de vitesse (k.p.h.)	Tachometer (k.p.h.)	Velocimetro (k.p.h.)	Smiths SC3305/05
A7, A10†	... —	Speedometer (m.p.h.)	Indicateur de vitesse (m.p.h.)	Tachometer (m.p.h.)	Velocimetro (m.p.h.)	Smiths SC3305/11
A7, A10*	... —	Speedometer (m.p.h.)	Indicateur de vitesse (m.p.h.)	Tachometer (m.p.h.)	Velocimetro (m.p.h.)	Smiths Z49313
A7, A10*	... —	Speedometer (k.p.h.)	Indicateur de vitesse (k.p.h.)	Tachometer (k.p.h.)	Velocimetro (k.p.h.)	Smiths Z49153
A7, A10*	... —	Speedometer (m.p.h.)	Indicateur de vitesse (m.p.h.)	Tachometer (m.p.h.)	Velocimetro (m.p.h.)	Smiths SC5301/20

†When Headlamp Cowl is fitted.
*When Headlamp Cowl is not fitted.

†Avec accessoire pour capot.
*Sans accessoire pour capot.

†Mit Haubebeschlag.
*Ohne Haubebeschlag.

†Con accesorio para capucha.
*Sin accesorio para capucha.

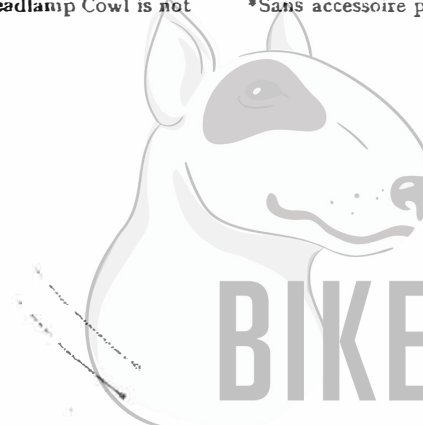

**CLASSIC
BIKE SPARES**